

Introduction of the First Year Ph.D. Student

Ing. Jiří Křupka

Institute of Machine and Industrial Design
Faculty of Mechanical Engineering
Brno University of Technology

Presentation of the first-year Ph.D. students
11th October 2017

Content

Introduction of myself

Education and academic qualification

Bachelor's thesis

Master's thesis

About my dissertation thesis

Teaching and learning activities

Introduction of myself

Jiří Křupka

- A4/401
- Tribology group

My hometown

- South Moravia – Brno (377400 people in 2015)

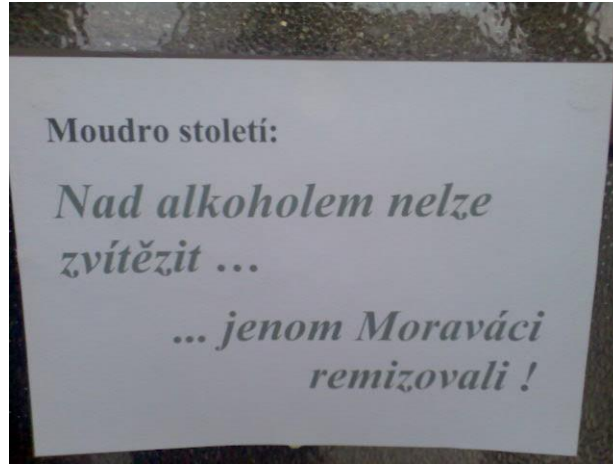

Map of Brno



The Red church



Dawn in Brno



Palacky hill winter view



Petrov church



Spilberk castle

Hobbies

Hobbies

- Playing keyboard
- Software programming
- 3D modelling (Solidworks, CATIA, Inventor)
- Repairing computers and cars
- Hiking
- Listening music and watching films
- Playing volleyball, tennis, table tennis, swimming



Maturita final thesis: AKU-drill

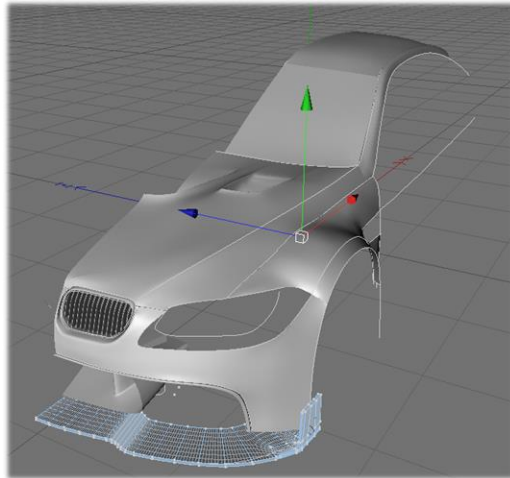

3D car modelling



Škoda factory and museum excursion (Mlada Boleslav 2016)



Hiking (Beskydy 2015)



Broken suspension spring exchange (Octavia I)



My keyboard



Twisted Rear wheel half axle (Mazda MX-5)

Education and academic qualification

High School

- Secondary Industrial School and High Technical School (SPŠS a VOŠ Sokolská 1, Brno)
- Specialization for Engineering - Computer graphics and Industrial design



Secondary Industrial School and High Technical School

University

- Bachelor's degree programme: Engineering - Machine and Equipment Construction at Faculty of Mechanical Engineering, Brno
- Master's degree programme: Mechanical Engineering - Automotive and Material Handling Engineering at Faculty of Mechanical Engineering, Brno



BUT Faculty of Mechanical Engineering

Education and academic qualification

High School

- Secondary Industrial School and High Technical School (SPŠS a VOŠ Sokolská 1, Brno)
- Specialization for Engineering - Computer graphics and Industrial design



University

- Bachelor's degree programme: Engineering - Machine and Equipment Construction at Faculty of Mechanical Engineering, Brno
- Master's degree programme: Mechanical Engineering - Automotive and Material Handling Engineering at Faculty of Mechanical Engineering, Brno



Bachelor's degree promotion (2015)



Master's degree promotion (2017)

Bachelor's Thesis

Magnetic separator

- Bachelor's degree programme: Engineering - Machine and Equipment Construction at Faculty of Mechanical Engineering, Brno
- Supervisor: doc. Ing. Jiří Malášek Ph.D

Abstract

- The aim of this bachelor thesis is to design the structural conception of magnetic separator designated to separate small-sized industrial waste.

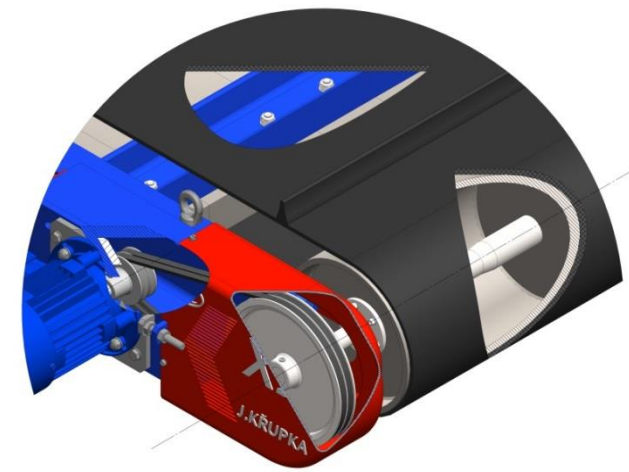

Magnetic separator inside view

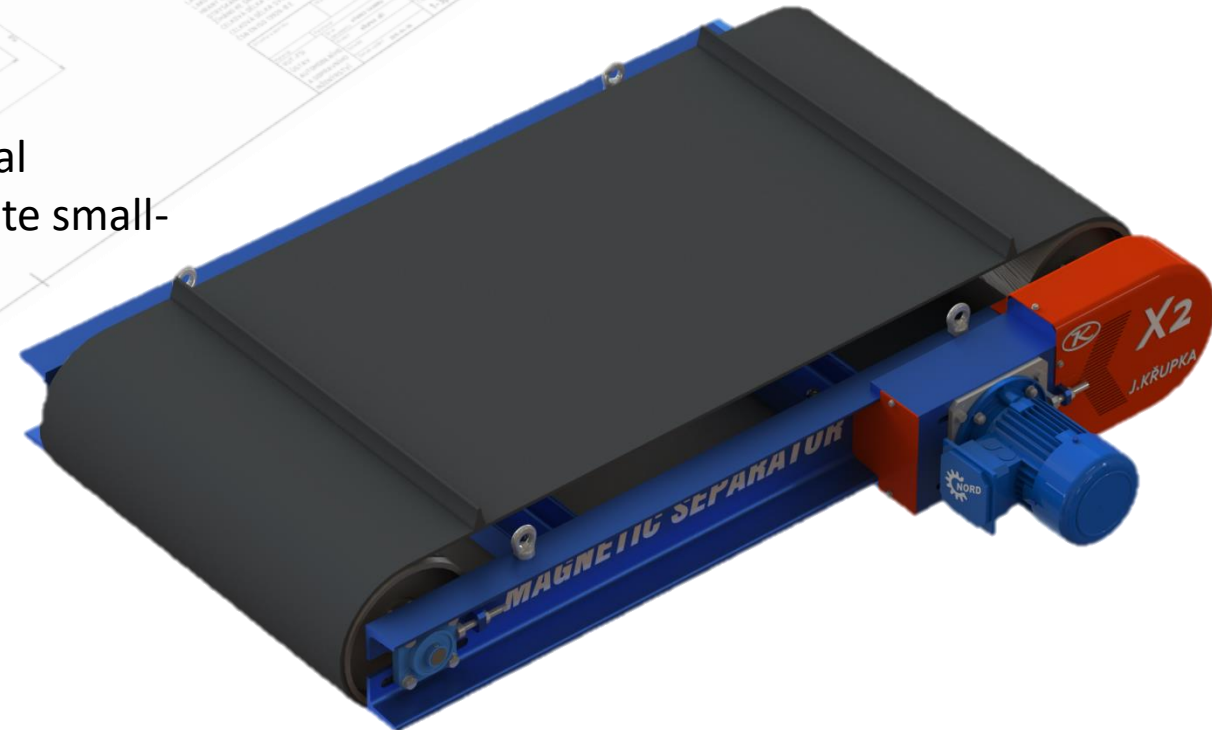
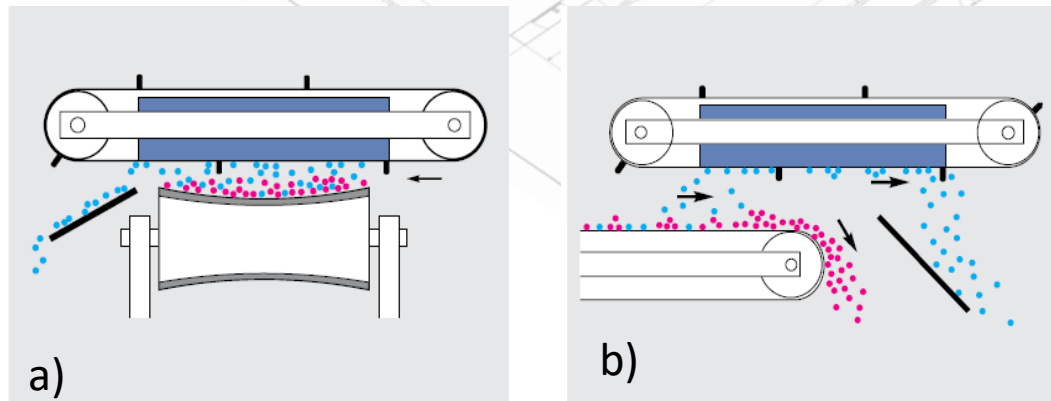

Magnetic separator

Magnetic separator - perpendicular orientation Magnetic separator - parallel orientation

Development of ventilation turbines

- Master's degree programme: Mechanical Engineering - Automotive and Material Handling Engineering at Faculty of Mechanical Engineering, Brno
- Supervisor: doc. Ing. Jiří Malášek Ph.D

Abstract:

Technical ventilation equipment is used for continuous ventilation of residential, commercial, industrial and agricultural interiors by natural or hybrid ventilation.

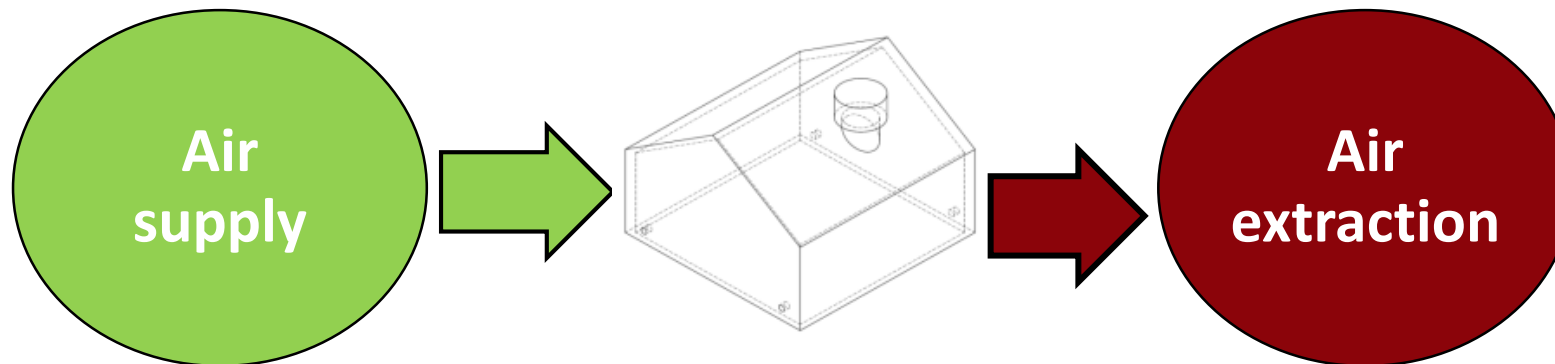

Ventilation diagram

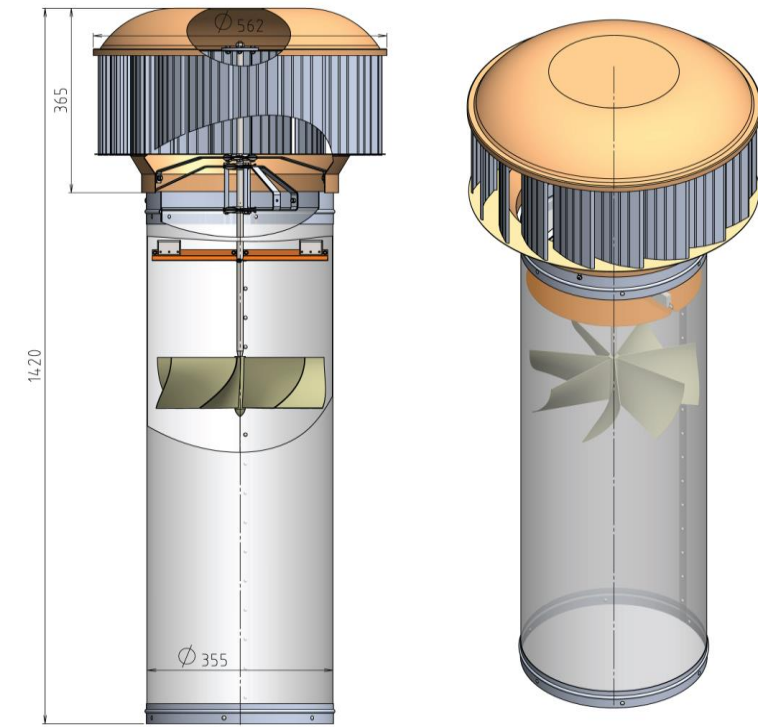

Visualisation of Edmonds Hurricane turbine assembly equipped with mechanical regulation



Ventilation turbine built on a roof of an apartment building (Lomanco BIB 14)

Development of ventilation turbines

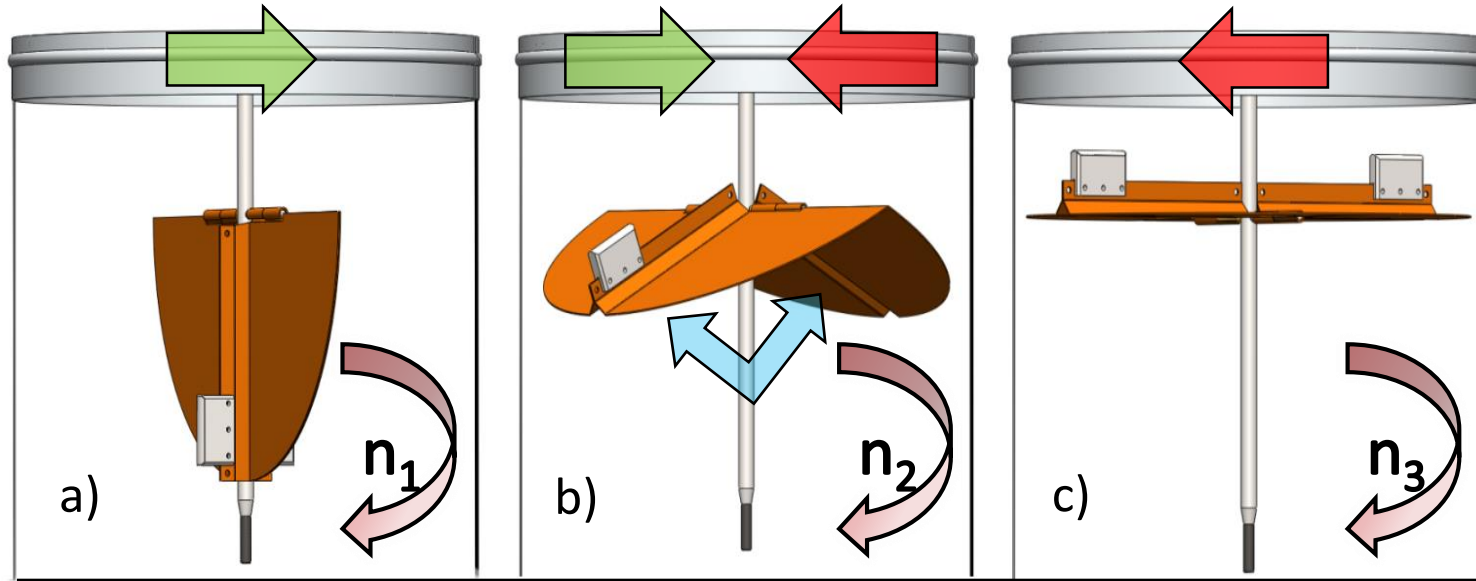

Mechanical regulation – Separated phases of valve movements: a) closed, b) general semi-position, c) opened

- Pipes closing process (valve opening)
 - Pipes opening process (valve closing)
- $n_1 < n_2 < n_3$
- Where: n – rounds $[s^{-1}]$

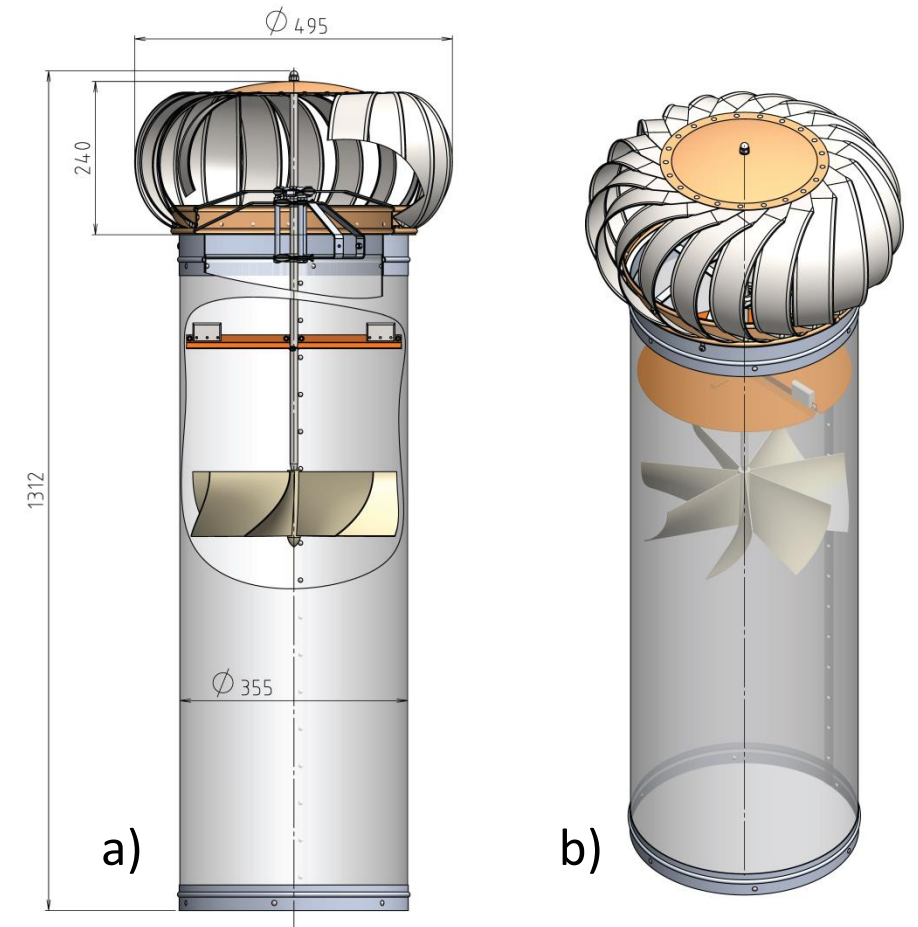

Visualization of VYTOZ-EKO turbine assembly equipped with mechanical regulation

Master's Thesis

MATLAB

SOLIDWORKS

VENTILATOR
GUI

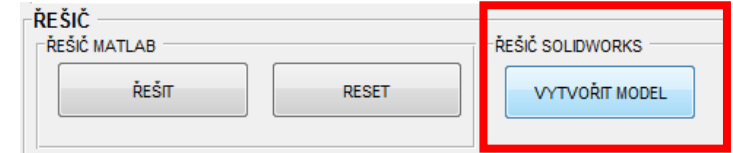

Solver panel: Ventilator 3D - model creation initialization

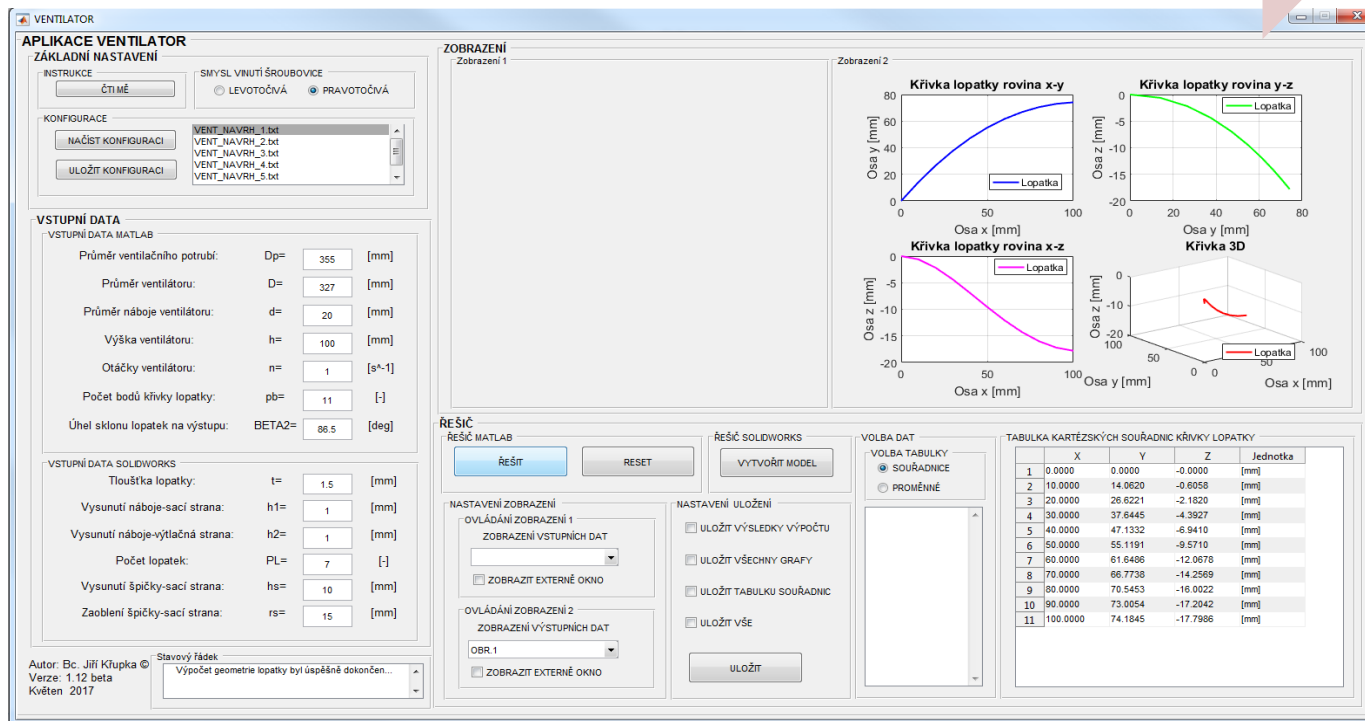

Application Ventilator (GUI), created by myself : This software connects MATLAB and Solidworks together

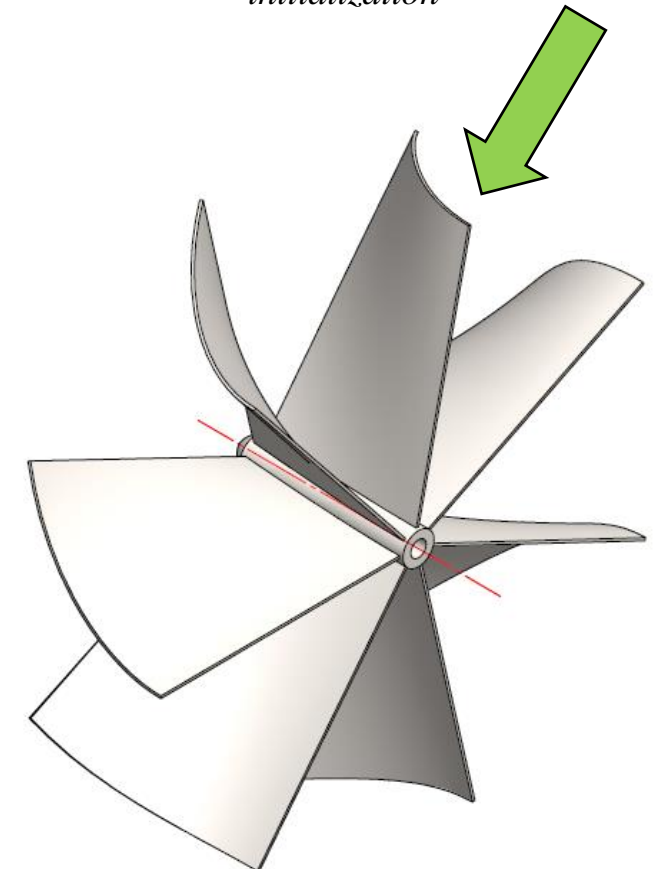

Final Ventilator 3D - model visualization

About my dissertation Thesis

Dissertation Thesis

- Study of the behavior the coated plastic teeth

Supervisor

- prof. Ing. Ivan Křupka, Ph.D

Expert consultant

- Ing. Petr Šperka, Ph.D



Teaching and learning activities

Teaching

- 1K – Basics of Machine Design
- 3CD – CAD (AutoCAD, Inventor)



Learning

- 9AJ – English for Ph.D. Students
- 9MOP – Methodologies of Scientific Work
- 9VPR – Research Project and its Management
- 9EHD – Elastohydrodynamics
- 9EXT – Experimental Methods in Tribology

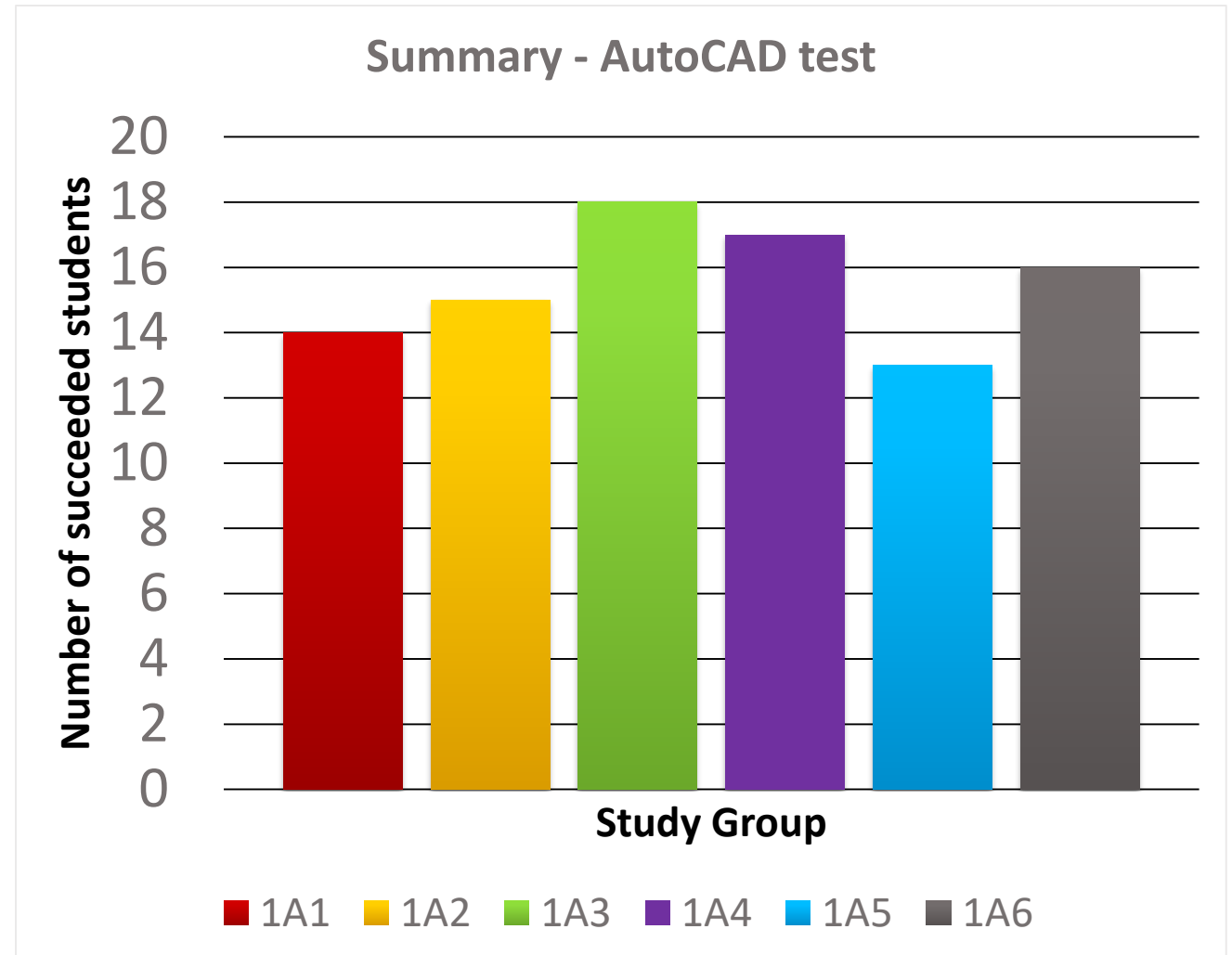

Thank you for attention

Ing. Jiří Křupka

Jiri.Krupka@vut.cz

<http://uk.fme.vutbr.cz/>