

# Activities at IMID

**Ondřej Macháček**

INSTITUTE OF MACHINE AND INDUSTRIAL DESIGN  
Faculty of Mechanical Engineering  
Brno University of Technology

Brno, 11 April, 2018



# Contents

## Research activities

- **Dissertation** “Magnetorheological strut for vibration isolation system of launch vehicle “
  - Introduction
  - Results
  - Conclusion
- **Other Projects**
  - Microfluidic system
  - Railway damper analysis



## Educational and other activities

# Introduction

## Structural vibration isolation systems – Payload adapters

- **Low efficiency** → **Mechanical vibration isolation systems**

esa



[Perez, 2014]

NASA

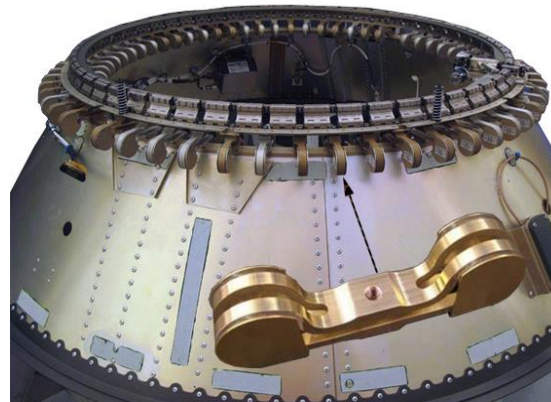

[Carantu, 2005]

SPACEX



[spacex.com]

# Introduction

## Mechanical vibration isolation systems – Stewart platform

Passive



[Rubsamen, 2003]

Active

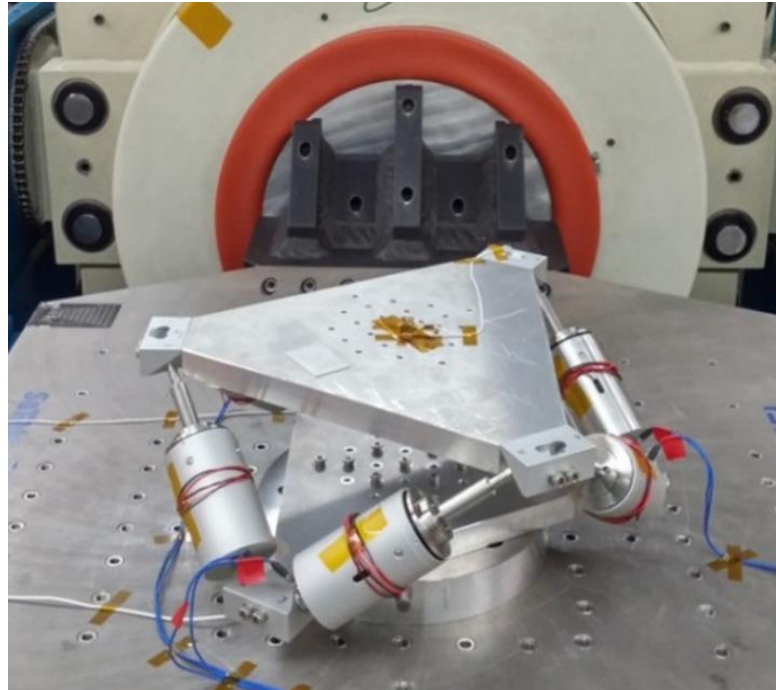

[Lee, 2015]

Semi - active

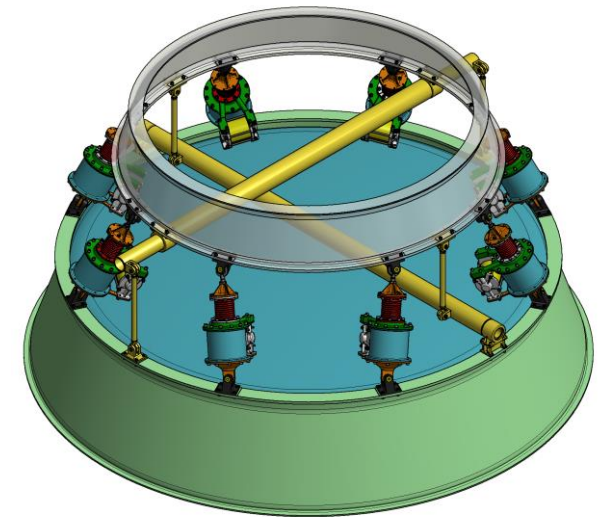

[esa.com]

# Introduction

## Transmissibility comparison of Passive, Active and SA vibration isolators

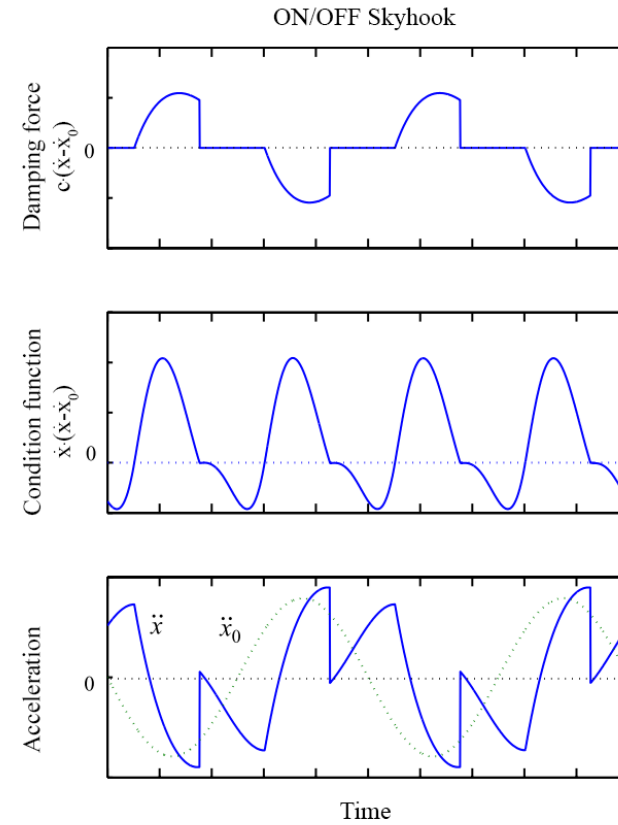
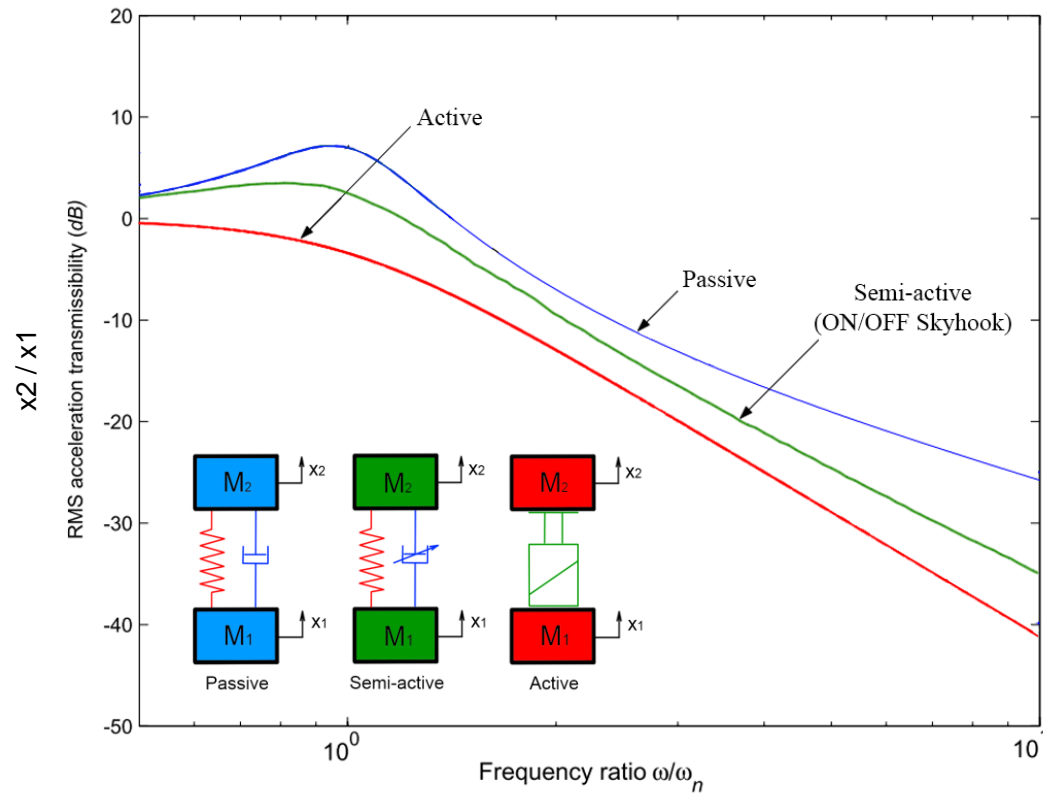

[Liu, 2005]

# Results

## Dynamic models

### Linear model - 22 DOF

Passive (no control of damping)

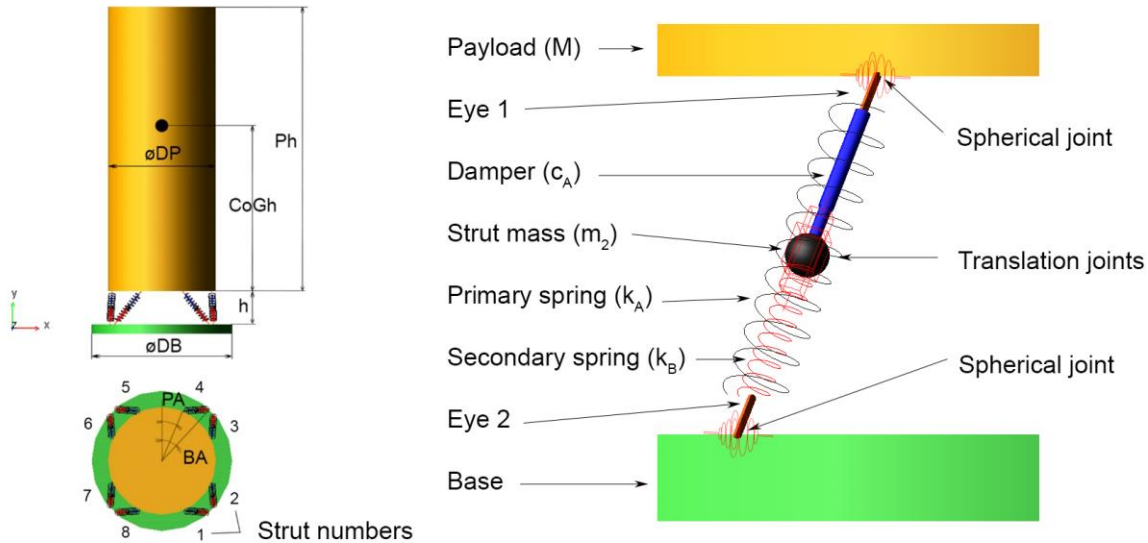

Outputs: Struts geometry  
Struts parameters  
Loads of 2 DOF model

### Non linear - 2 DOF

Semi-active control of damping

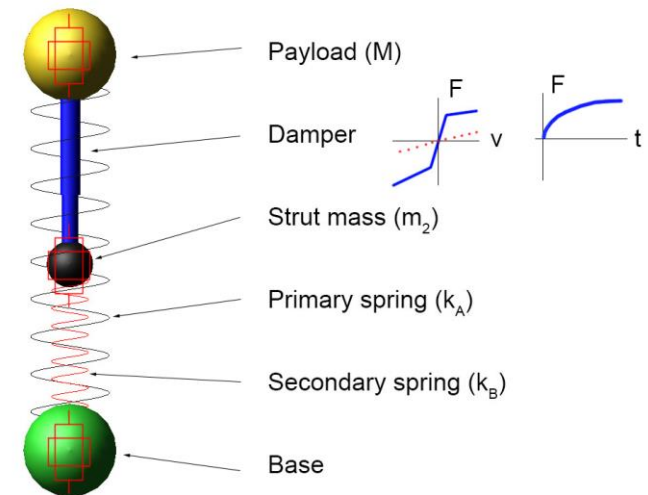

Outputs: Parameters of SA control  
Response time  
Dynamic force range

# Results

## Semi-active control by algorithm “ON/OFF Skyhook“

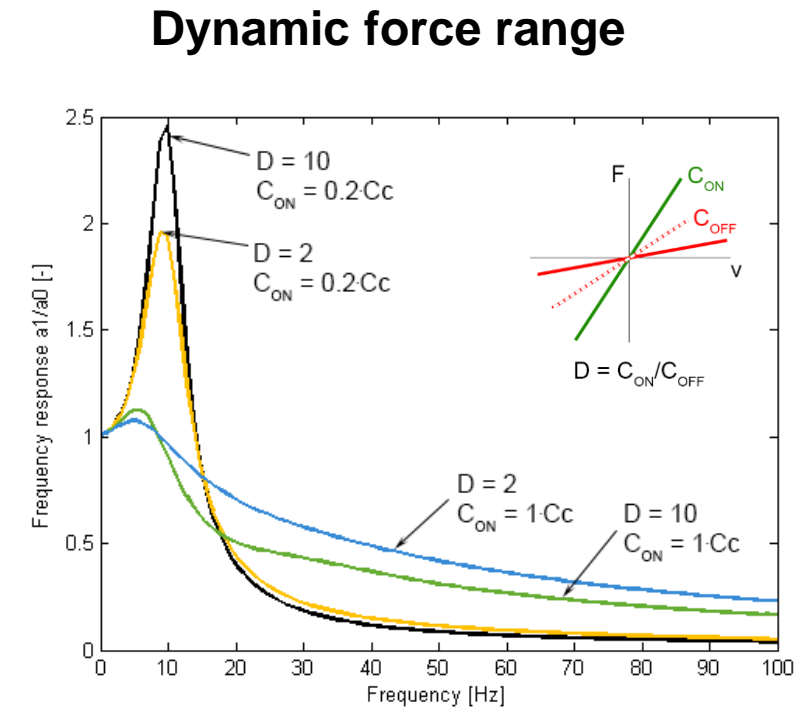
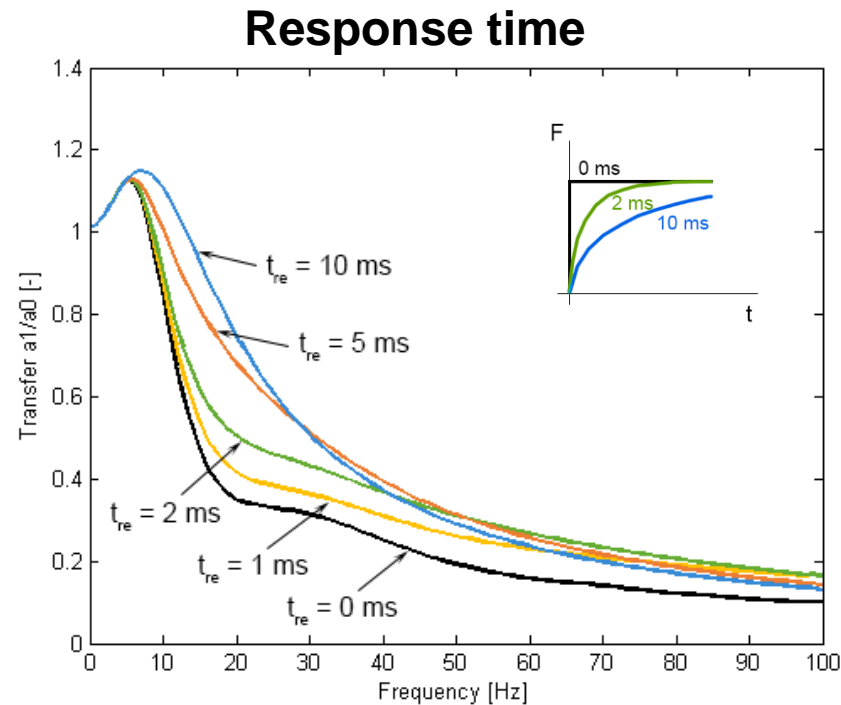

MACHÁČEK, O.; KUBÍK, M.; NOVÁK, P. A NEW METHOD OF MAGNETORHEOLOGICAL DAMPER QUALITY EVALUATION. In ENGINEERING MECHANICS 2017. Praha: Institute of Thermomechanics Academy of Sciences of the Czech Republic, 2017. s. 594-597. ISBN: 978-80-214-5497-2.

# Results

## The experimental strut demonstrator

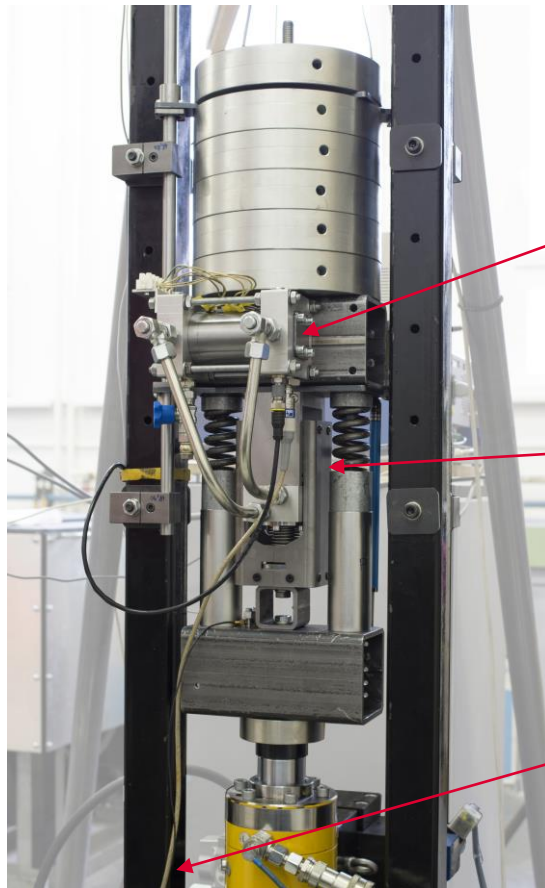

KUBÍK, M.; MACHÁČEK, O.; ROUPEC, J.; STRECKER, Z.; MAZŮREK, I.  
Design and testing of magnetorheological valve with fast force response time and great dynamic force range. *SMART MATERIALS & STRUCTURES*, 2017, roč. 26, č. 4, s. 1-10. ISSN: 0964-1726.

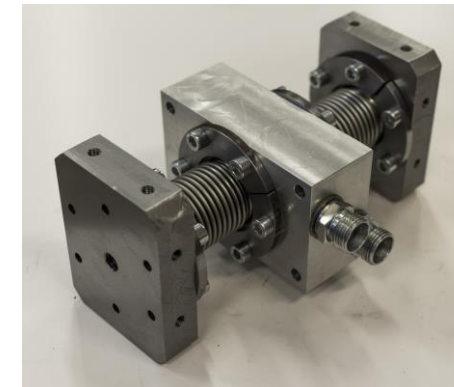

MACHÁČEK, O.; KUBÍK, M.; ROUPEC, J.; STRECKER, Z.; MAZŮREK, I.  
Design of Frictionless Magnetorheological Damper with High Dynamic Force Range. *ADVANCES IN MECHANICAL ENGINEERING*



STRECKER, Z. ; ROUPEC, J.; MAZŮREK, I. .; MACHÁČEK, O.; KUBÍK, M.  
Skyhook Controlled Three Parameter Semiactive Damping System with Fast Magnetorheological Valve. *ADVANCES IN MECHANICAL ENGINEERING*

# Results

## The experimental strut demonstrator

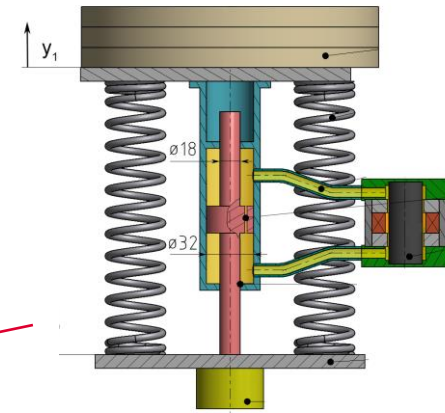
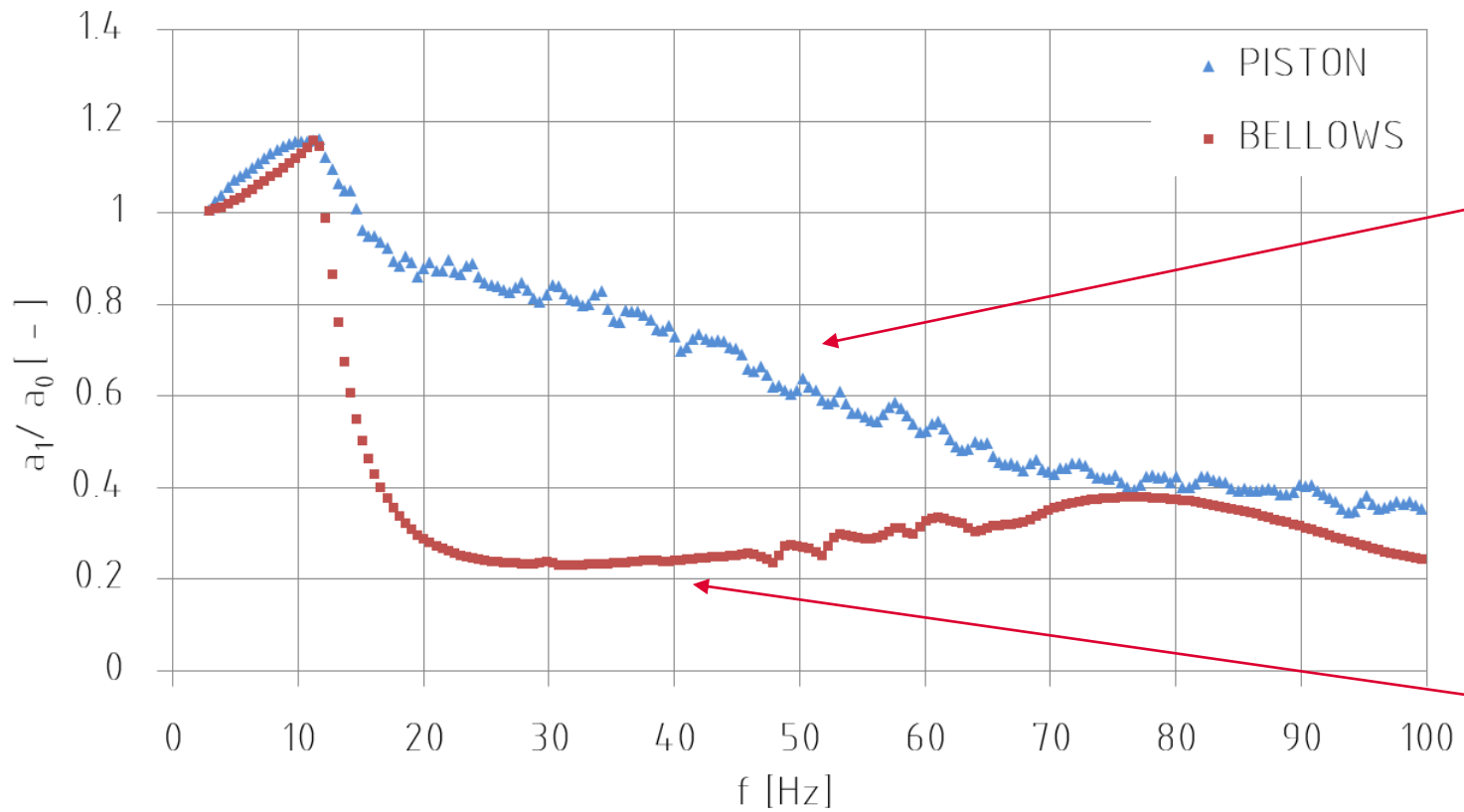

PISTON UNIT  
High friction  
 $D=4$

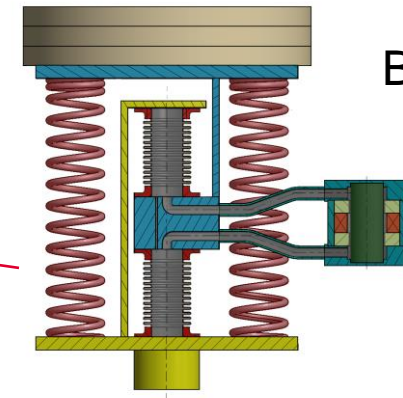

BELLOWS UNIT  
No friction  
 $D=9$

# Results

## Vibration isolator with metal bellows

Low damping

$$k_1 \cdot x \gg c \cdot \dot{x}$$

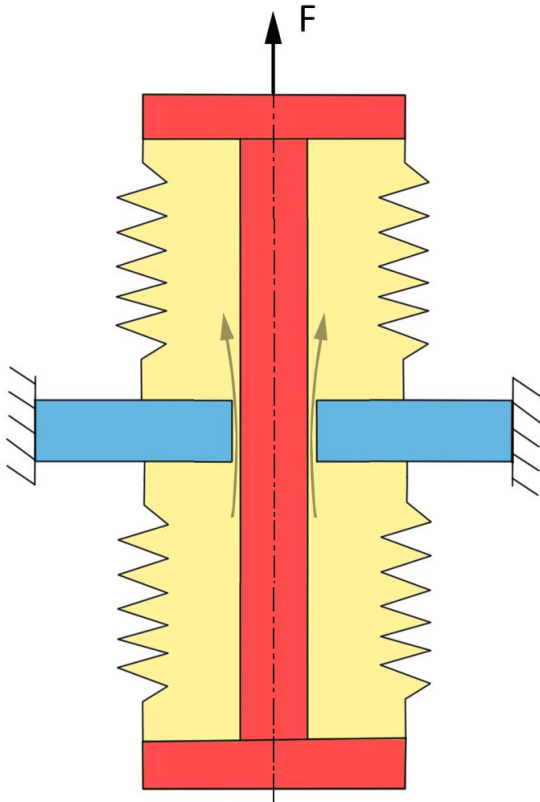

High damping

$$k_1 \cdot x \ll c \cdot \dot{x}$$

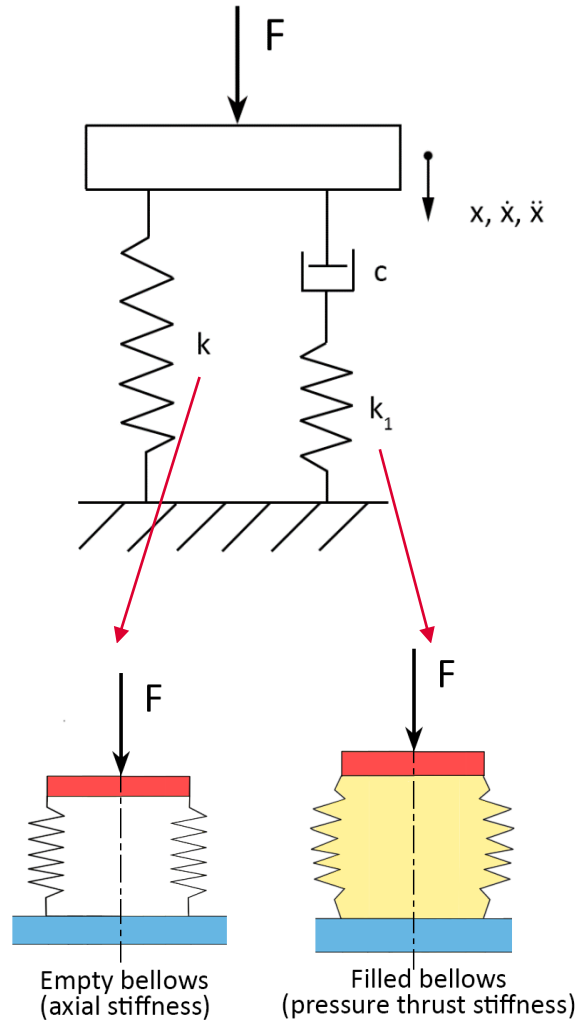
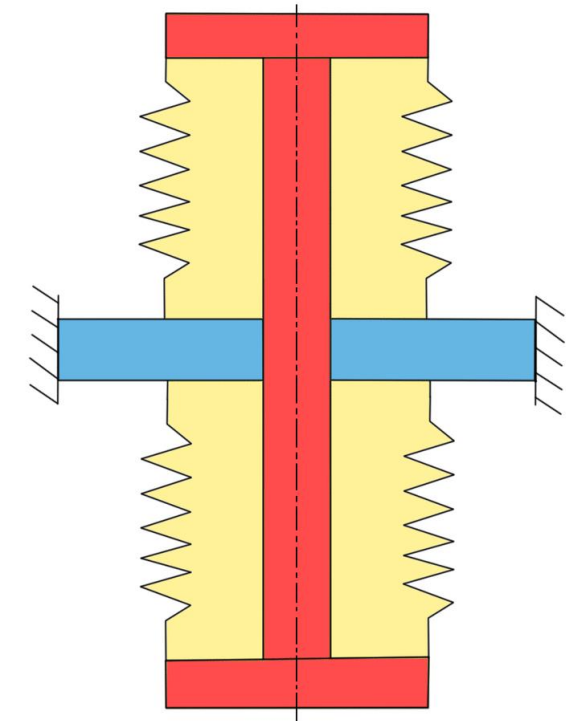

# Introduction

## Vibration isolator with metal bellows

Available in product list

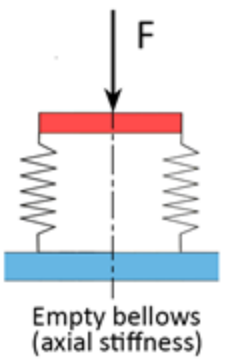

Unavailable in product list

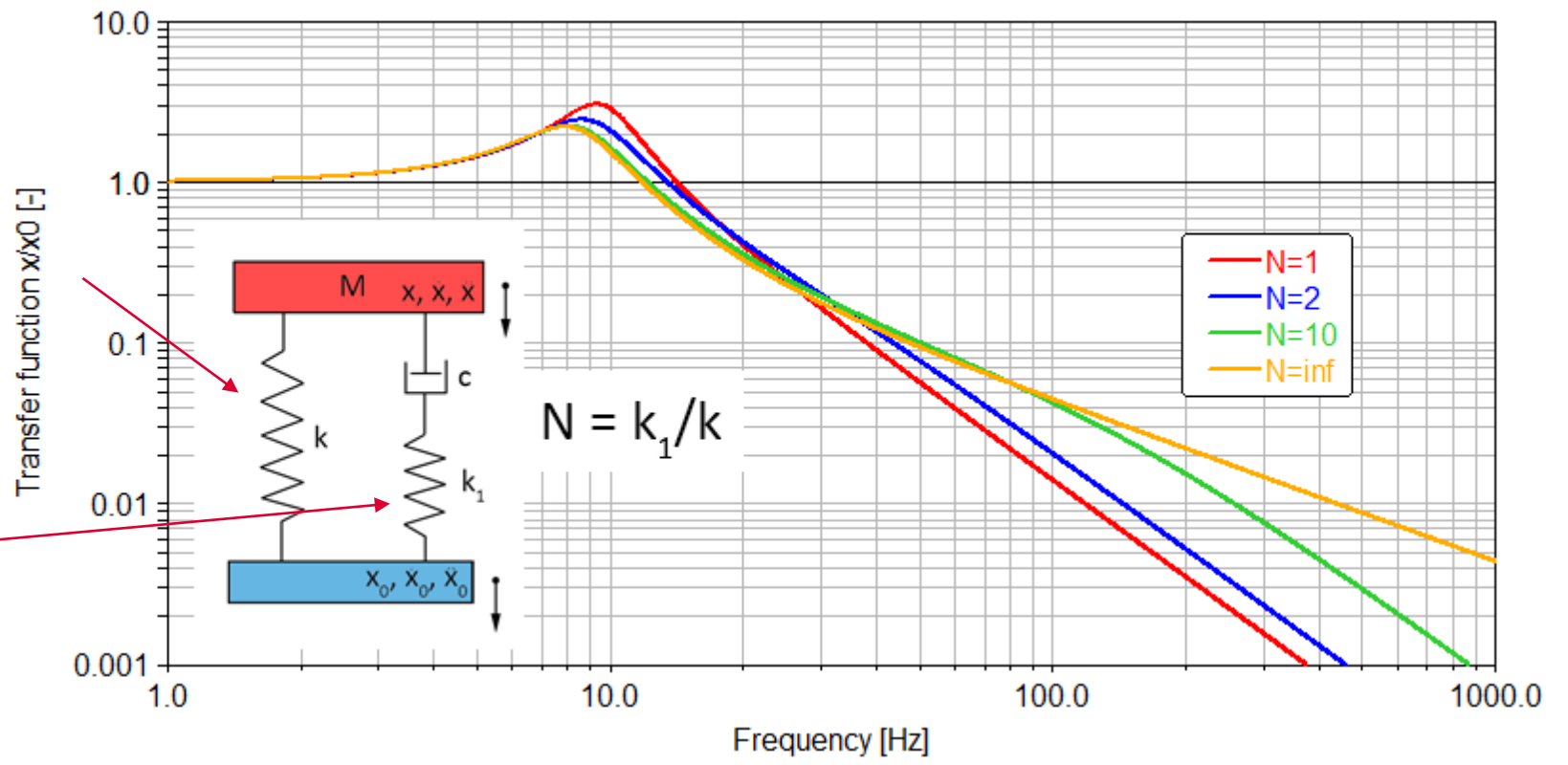
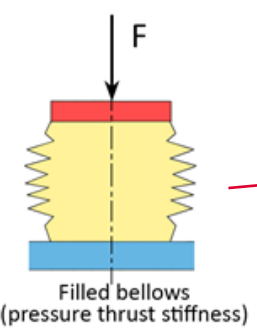

# Results

## Metal bellows

FEM model of metal bellows was verified by Measurement

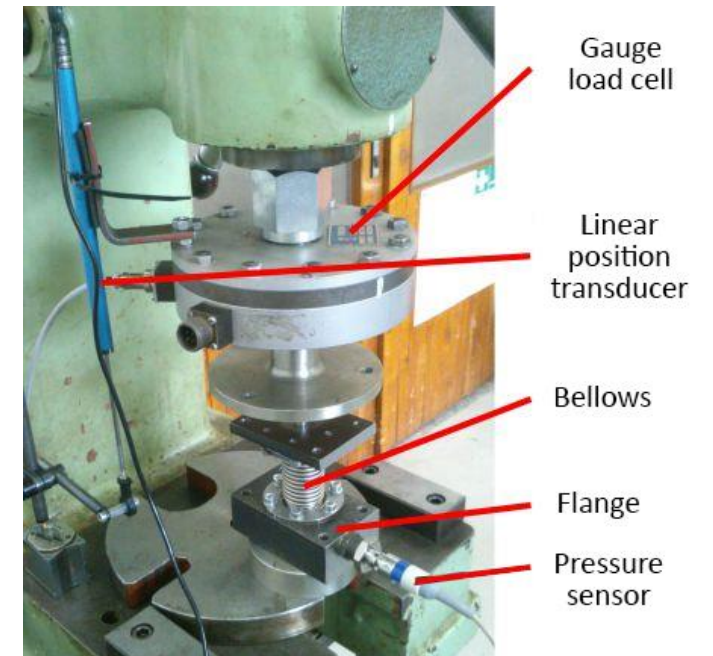
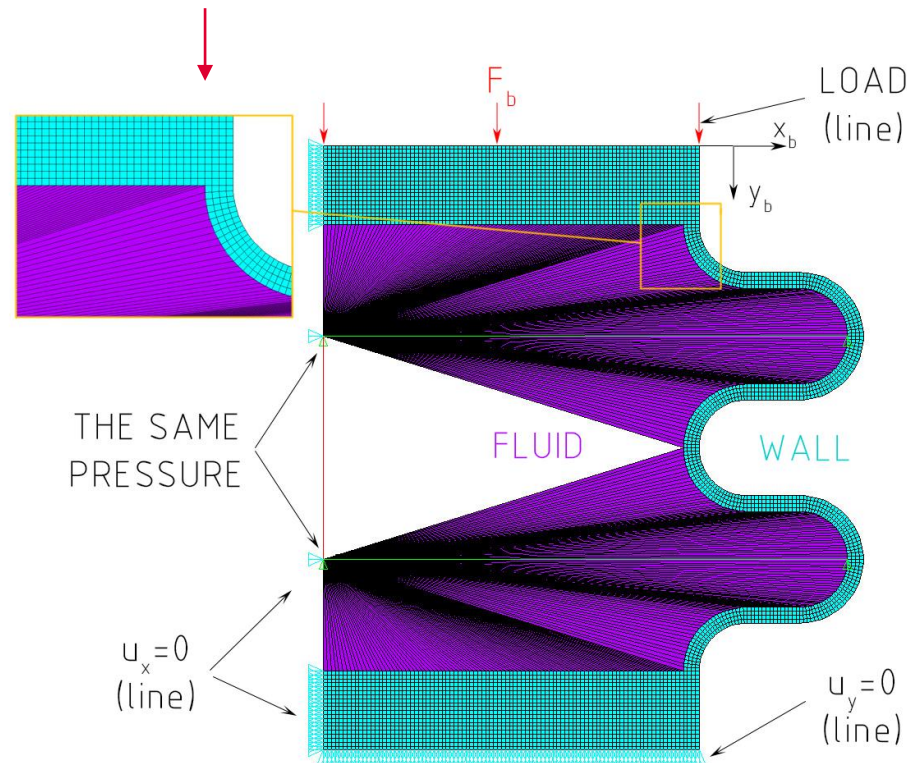

# Results

## Axial and Pressure thrust stiffness of metal bellows

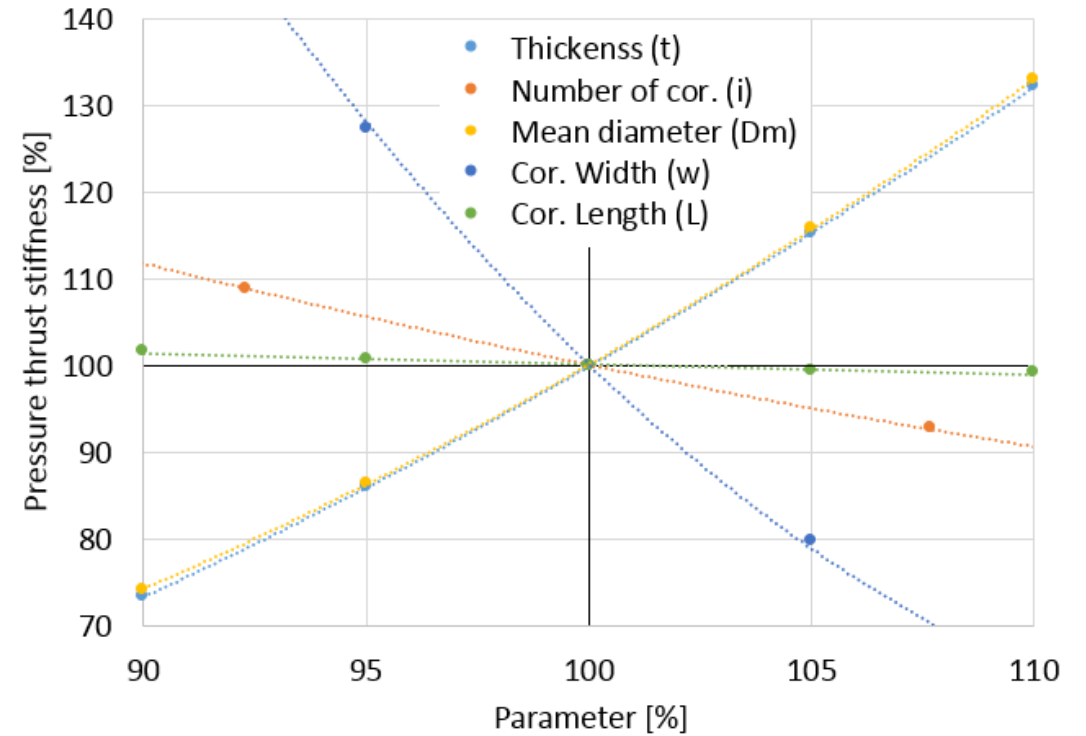
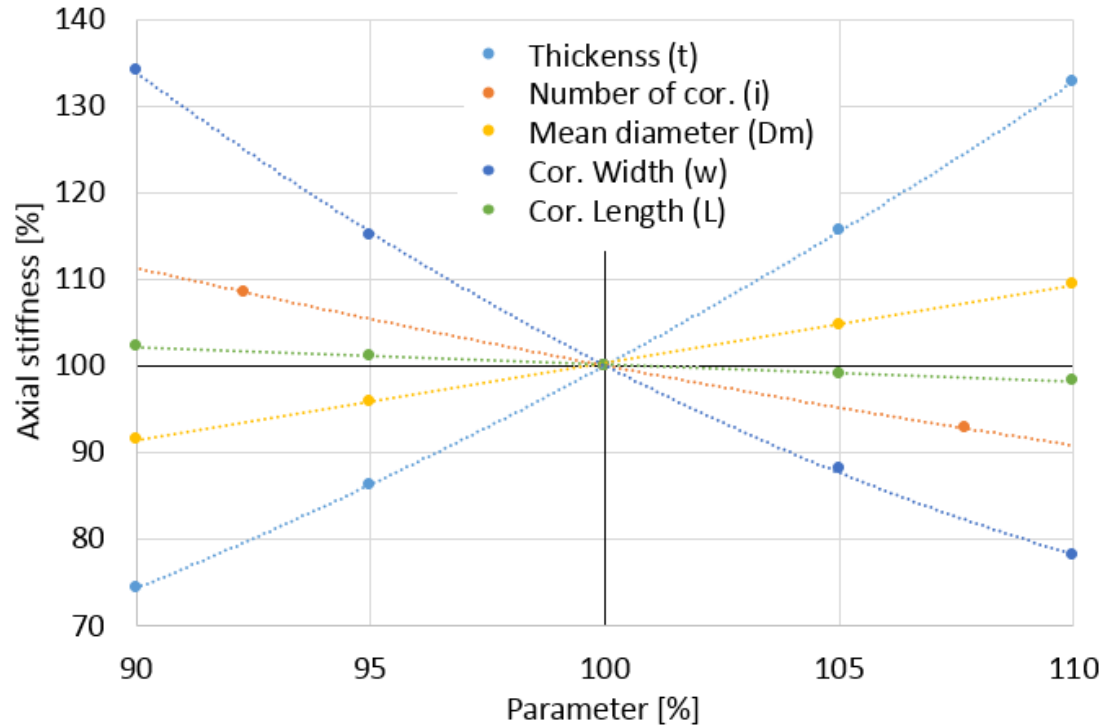

# Results

## Axial and Pressure thrust stiffness of metal bellows

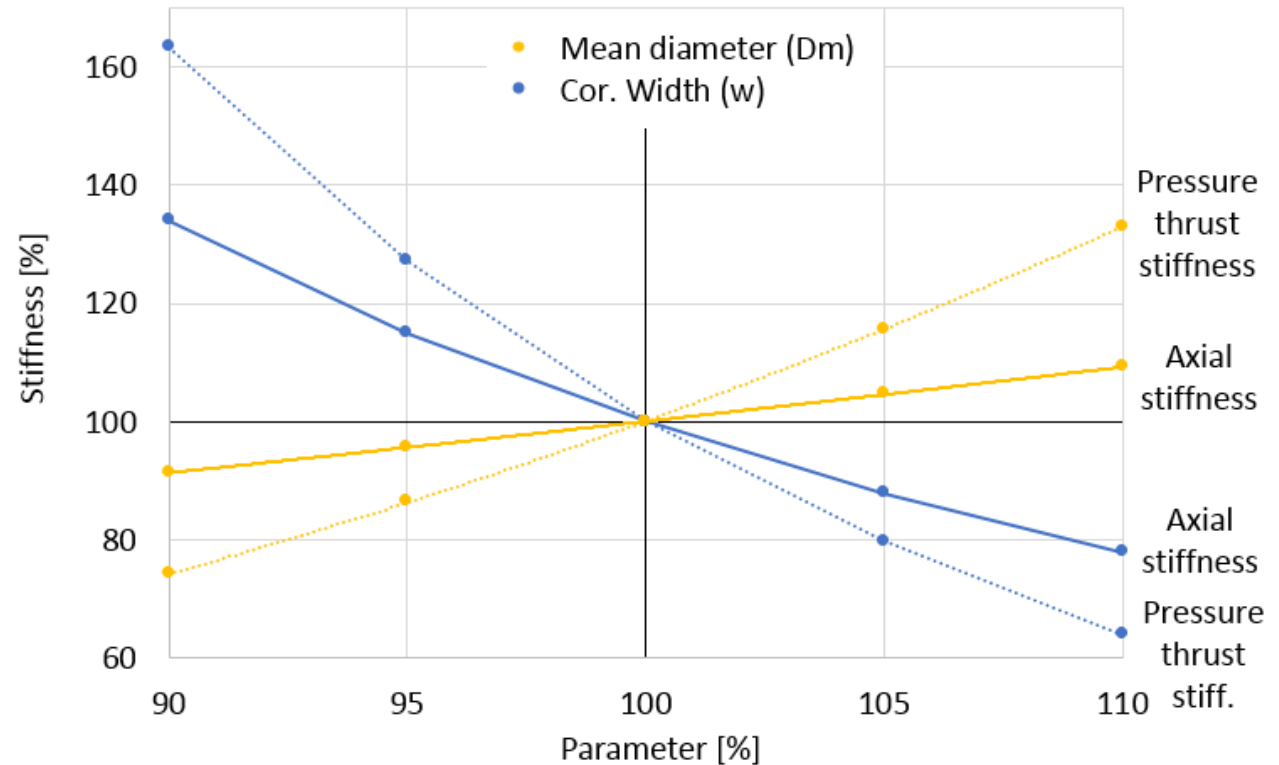
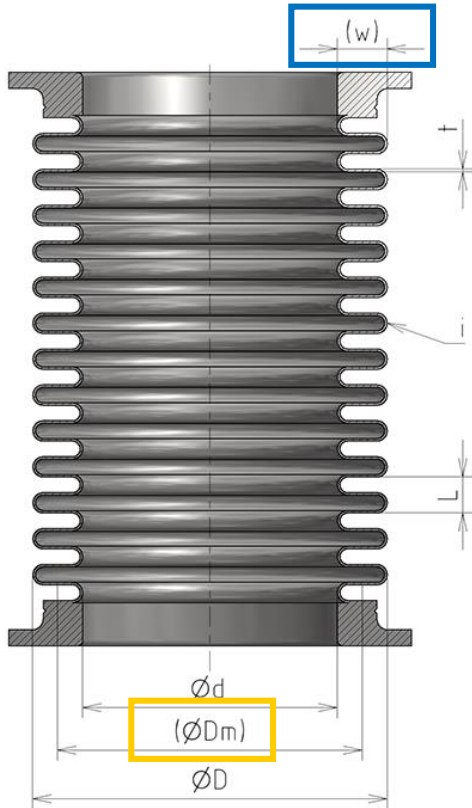

MACHÁČEK, O.; KUBÍK, M.; STRECKER, Z.; ROUPEK, J.; NOVÁK, P.; MAZŮREK, I. Axial and Pressure Thrust Stiffness of Metal Bellows for Vibration Isolators. In *MATEC Web of Conferences*. MATEC Web of Conferences. 2018. s. 1-5. ISSN: 2261-236X.

# Results

## Conference in Kuala Lumpur



# Conclusion

## Aims of the Thesis

- Create dynamic model of Vibration Isolation system ✓
- Design experimental strut for tests ✓
- Confirm the function of the strut by the experiment ✓
- Verify models and optimize the strut design parameters based on simulations 90%
- Finalize the strut design with regard to materials and technology 30%

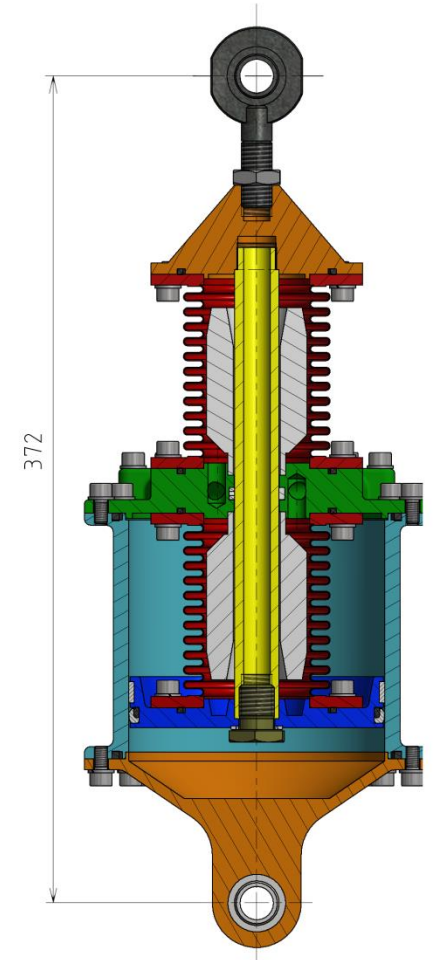
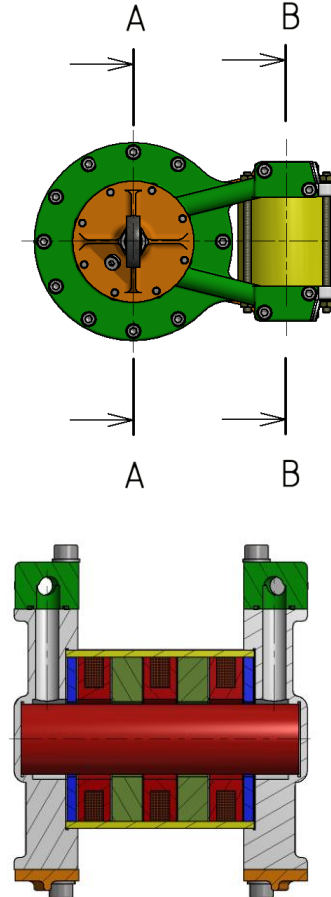
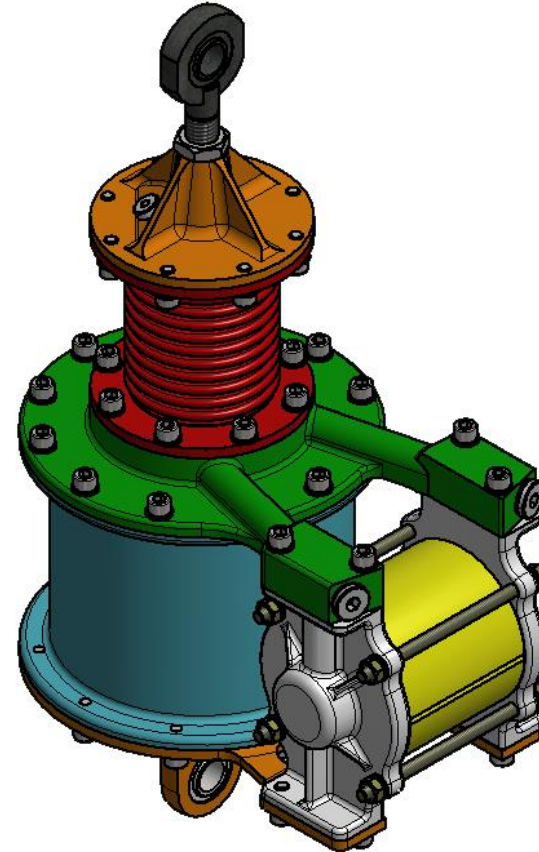
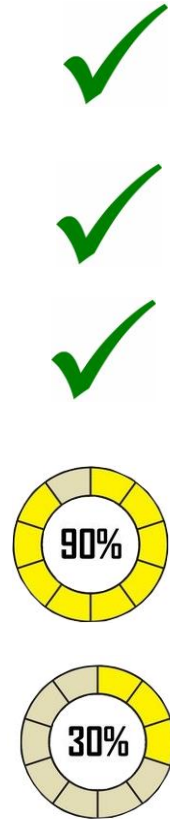

# Other projects

## Microfluidic system – capturing of magnetic particles in biological fluid



Internship 2016



Univerzita  
Pardubice

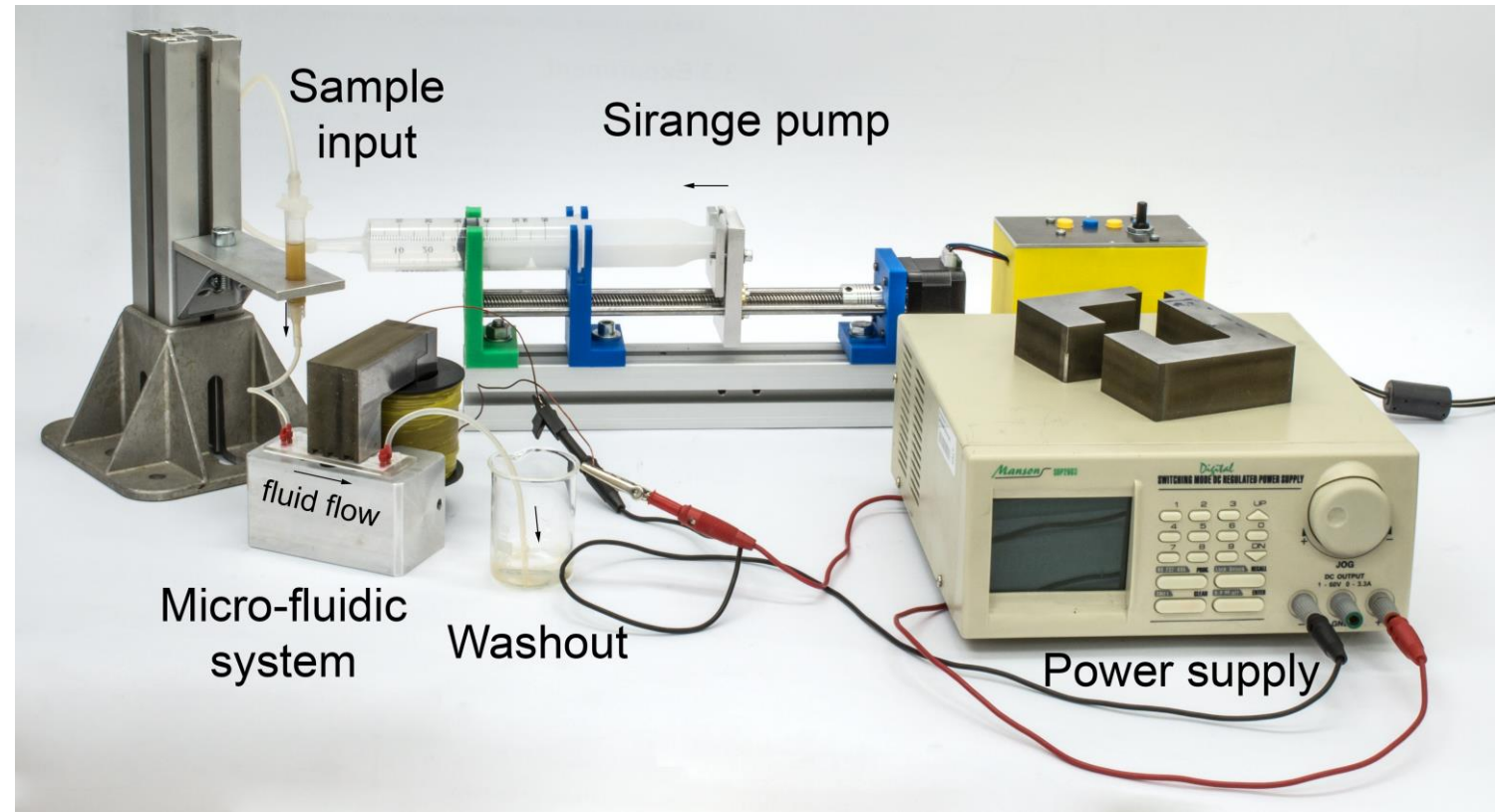

# Microfluidic system

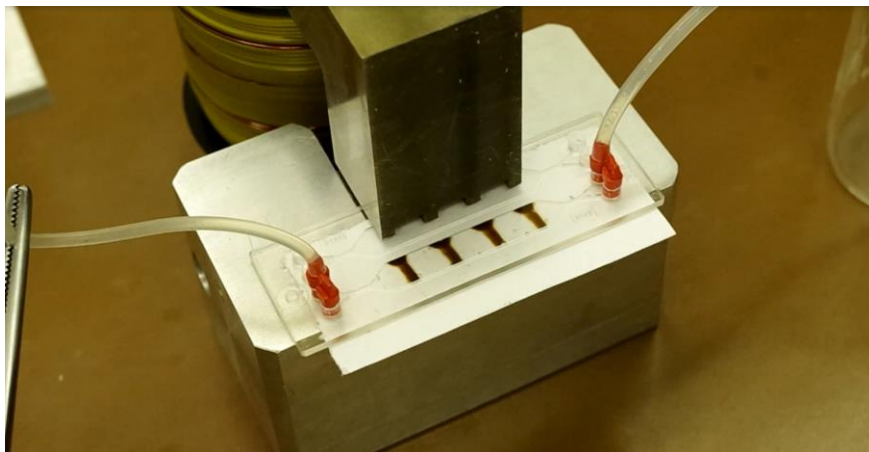
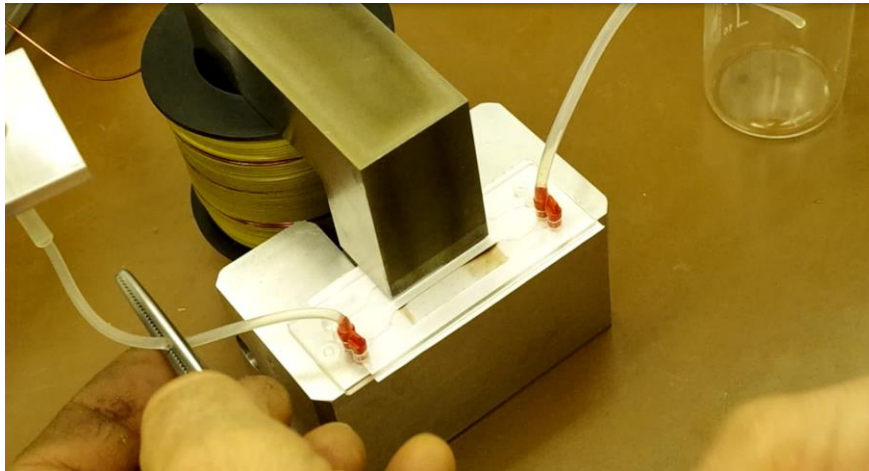

## Design of grooved pole pieces using Magnetostatic FEM model

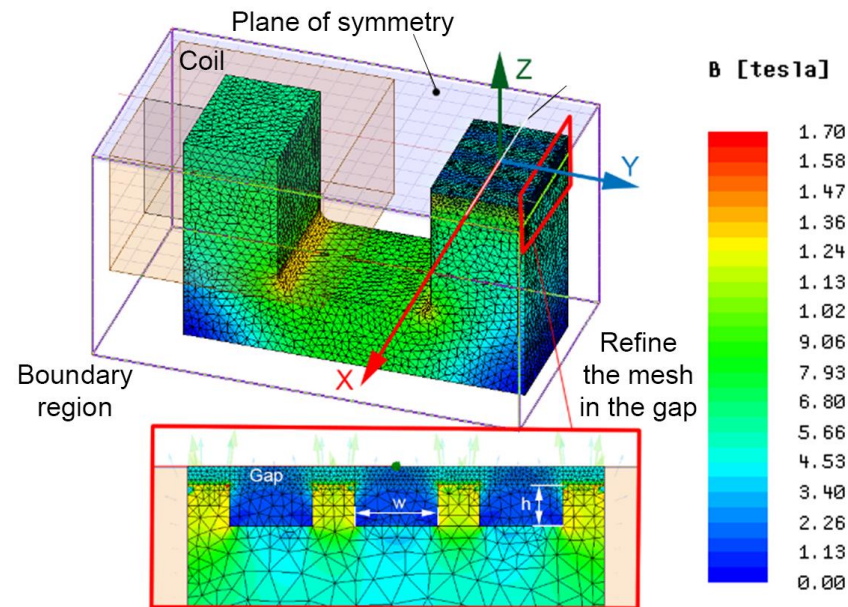

## The model was verified by measurement

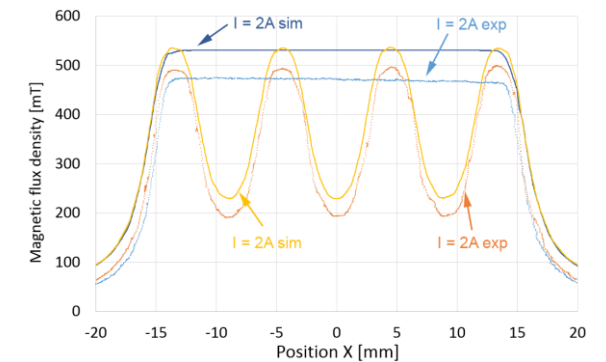
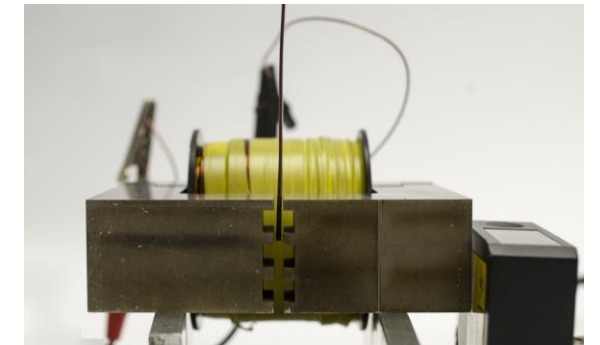

MACHÁČEK, O.; KUBÍK, M.; ROUPEC, J; STRECKER, Z; MAZŮREK, I. Micro-fluidic System with Grooved Pole Pieces of Magnetic Circuit. In *ENGINEERING MECHANICS 2018*

# Other projects

## Railway damper analysis

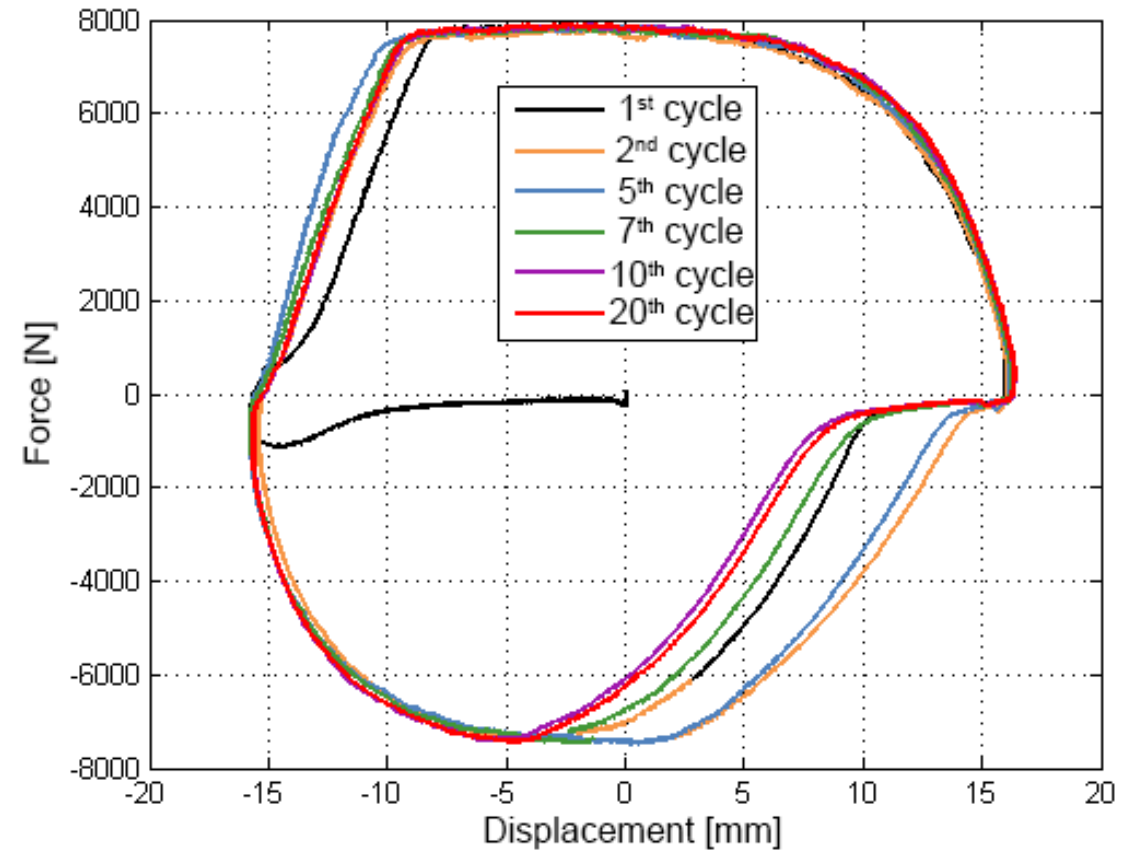
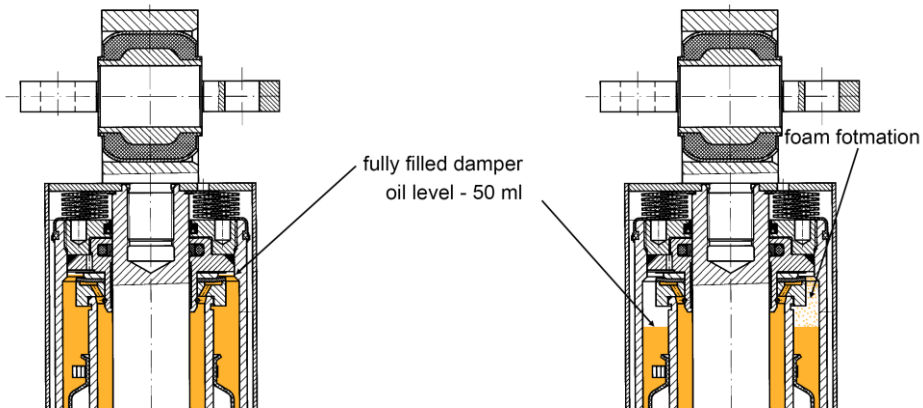

# Railway damper analysis

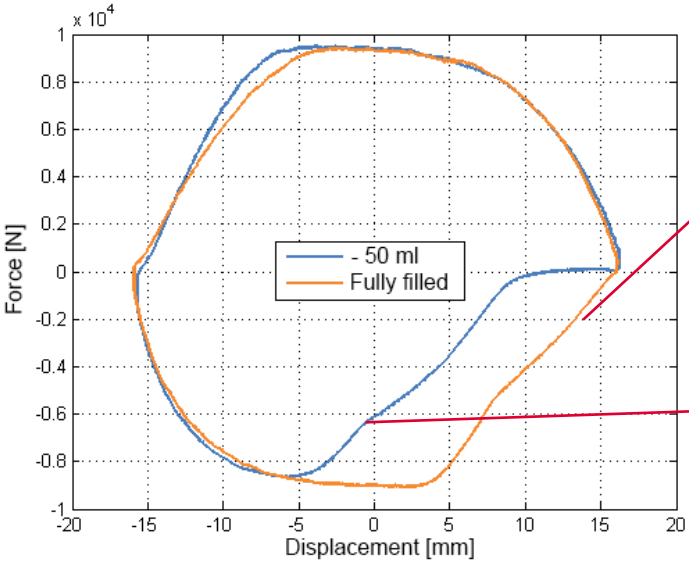
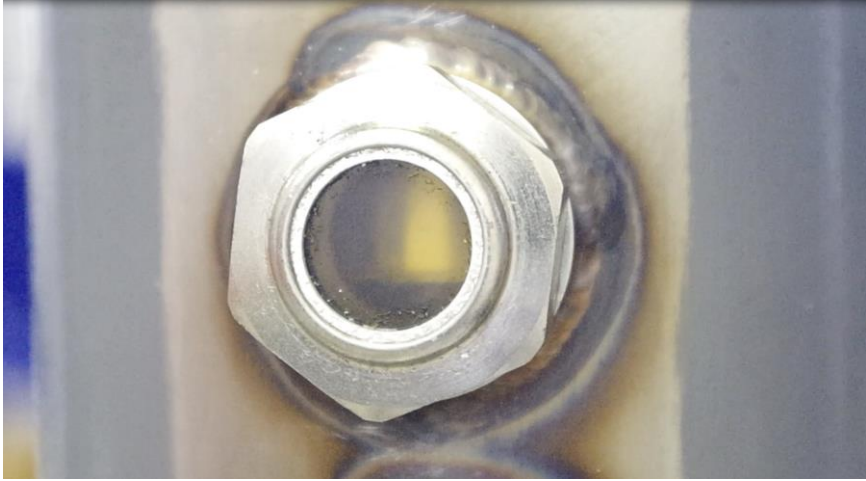
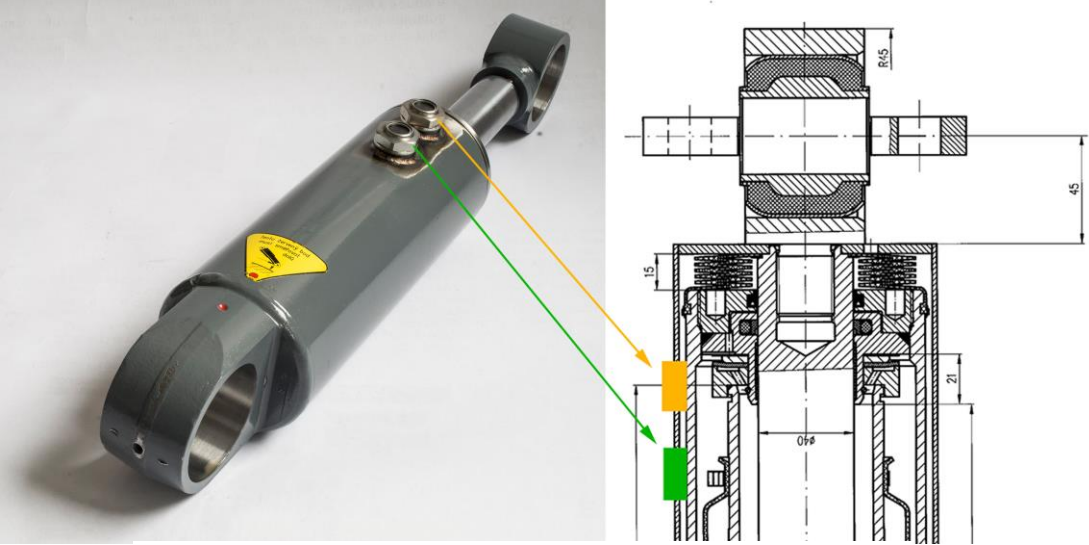



# Publications and patent

5x IF

11x WoS

1x patent

## 2018

MACHÁČEK, O.; KUBÍK, M.; STRECKER, Z.; ROUPEC, J.; NOVÁK, P.; MAZŮREK, I. Axial and Pressure Thrust Stiffness of Metal Bellows for Vibration Isolators

KUBÍK, M.; MACHÁČEK, O.; STRECKER, Z.; ROUPEC, J.; NOVÁK, P.; MAZŮREK, I. Transient magnetic model of magnetorheological damper and its experimental verification

## 2017

MACHÁČEK, O.; KUBÍK, M.; NOVÁK, P. A new method of magnetorheological damper quality evaluation

KUBÍK, M.; MACHÁČEK, O.; ROUPEC, J.; STRECKER, Z.; MAZŮREK, I. Design and testing of magnetorheological valve with fast force response time and great dynamic force range.

KUBÍK, M.; MACHÁČEK, O.; STRECKER, Z.; ROUPEC, J.; MAZŮREK, I. Dynamic viscosity of commercially available magnetorheological fluids..

ROUPEC, J.; BERKA, P.; MAZŮREK, I.; STRECKER, Z.; KUBÍK, M.; MACHÁČEK, O., ANDANI, M. Taheri. A novel method for measurement of MR fluid sedimentation and its experimental verification.

ROUPEC, J.; MAZŮREK, I.; STRECKER, Z.; KUBÍK, M.; MACHÁČEK, O. Tensile strength of pure iron samples manufactured by selective laser melting method

STRECKER, Z.; STRMISKA, T.; ROUPEC, J.; KUBÍK, M.; MACHÁČEK, O. Design of fast magnetorheological damper using soft magnetic composites

KLAPKA, M.; MAZŮREK, I.; MACHÁČEK, O.; KUBÍK, M. Reinvention of the EUSAMA diagnostic methodology

## 2016

MACHÁČEK, O.; KUBÍK, M.; MAZŮREK, I.; STRECKER, Z.; ROUPEC, J. Frictionless Bellows Unit Connected with the Magnetorheological Valve.

STRECKER, Z.; ČÍPEK, P.; ROUPEC, J.; MACHÁČEK, O.; KUBÍK, M. Testing of Car Suspension With Fast MR Damper, Controlled by Modified Groundhook Algorithm

KLAPKA, M.; MAZŮREK, I.; MACHÁČEK, O. Analysis of causes of false- negative evaluation of eusama methodology for suspension assessment

KLAPKA, M.; MAZŮREK, I.; MACHÁČEK, O.; KUBÍK, M. Twilight of the EUSAMA diagnostic methodology.

KUBÍK, M.; MACHÁČEK, O.; STRECKER, Z.; ROUPEC, J.; MAZŮREK, I. Hydraulic resistance of magnetorheological damper viscous bypass gap

ROUPEC, J.; MAZŮREK, I.; STRECKER, Z.; KUBÍK, M.; MACHÁČEK, O. Temperature dependence of magnetorheological fluid yield stress and Bingham viscosity

## 2015

STRECKER, Z.; MAZŮREK, I.; ROUPEC, J.; MACHÁČEK, O.; KUBÍK, M.; KLAPKA, M. Design of magnetorheological damper, with short time response

KUBÍK, M.; STRECKER, Z.; ROUPEC, J.; MAZŮREK, I.; MACHÁČEK, O.; PALOUŠEK, D.; KOUTNÝ, D.: Vysoké učení technické v Brně: *Skelet jádra tvořeného pruty z feromagnetického materiálu*. 307249, patent. (2018)

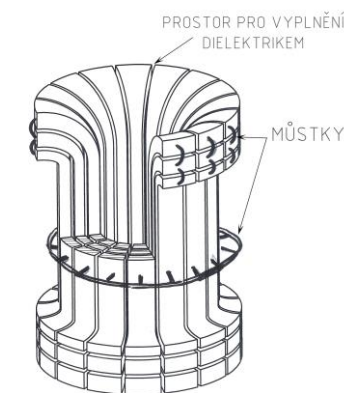

# Thank you for your attention

**Ondřej Macháček**

[ondrej.machacek@vutbr.cz](mailto:ondrej.machacek@vutbr.cz)



INSTITUTE OF MACHINE  
AND INDUSTRIAL DESIGN

[www.ustavkonstruovani.cz](http://www.ustavkonstruovani.cz)