

Effect of surface texturing on friction and film thickness under starved lubrication conditions

Fadi Ali



**Institute of Machine
and Industrial Design**

Institute of Machine and Industrial Design – Department of Tribology

Faculty of Mechanical Engineering
Brno University of Technology

Ph.D. Thesis Defense

July 24th, 2015, Brno

- Non-conformal contacts
- Elastohydrodynamic lubrication
- Starved lubrication
- Micro-textures

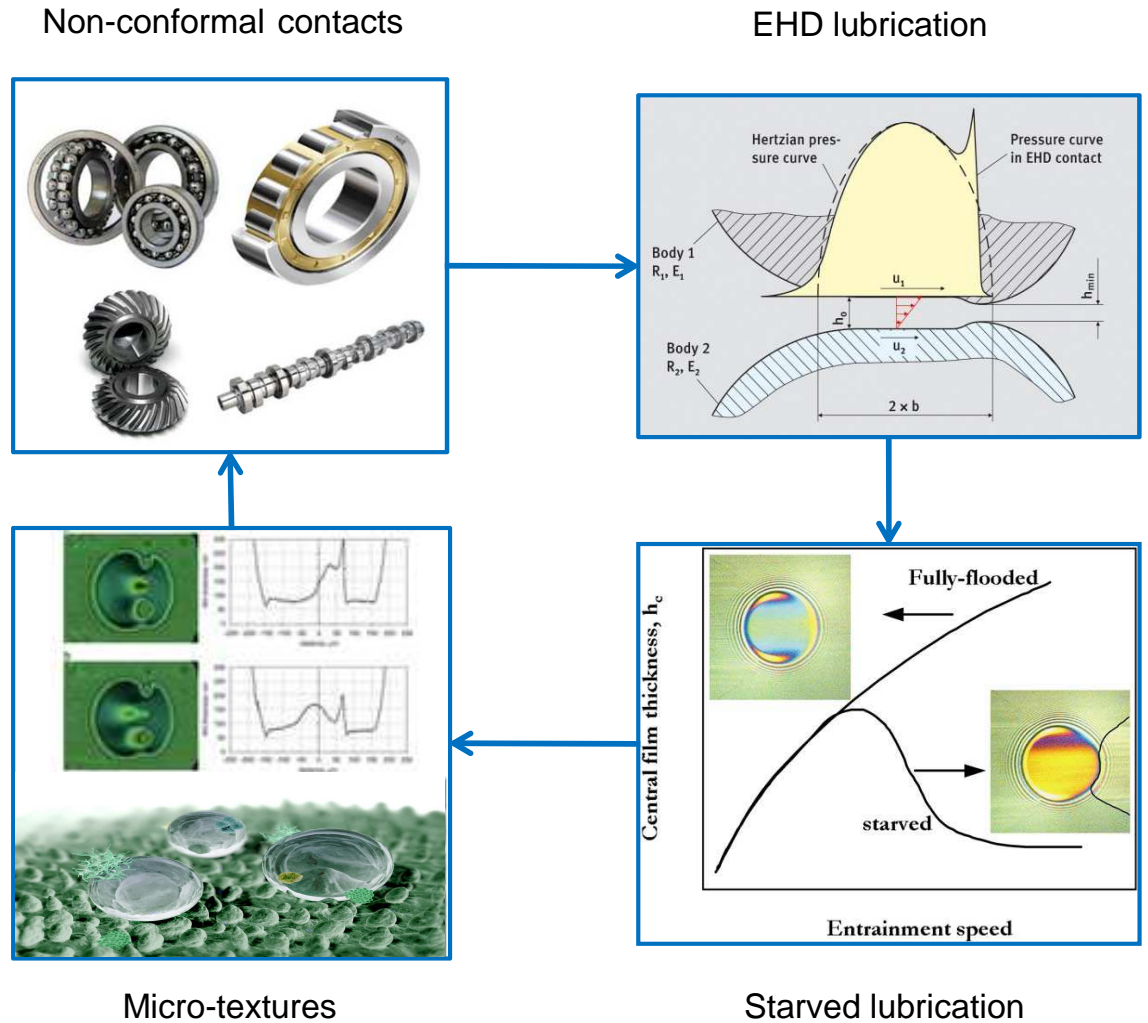

STATE OF THE ART

Andersson et al. 2007

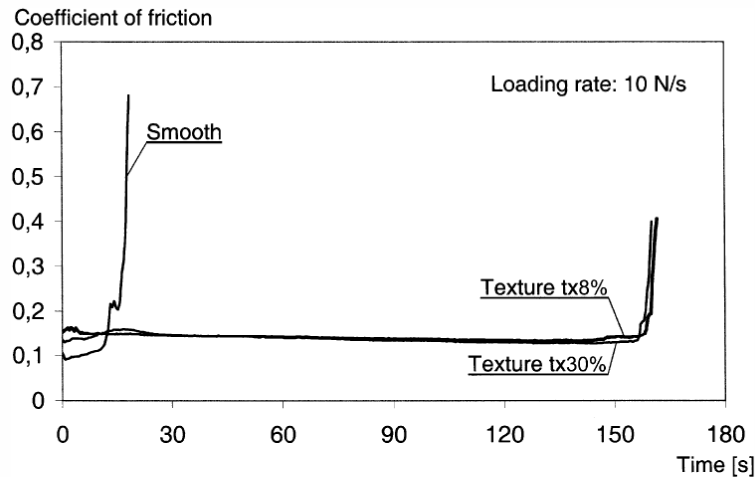
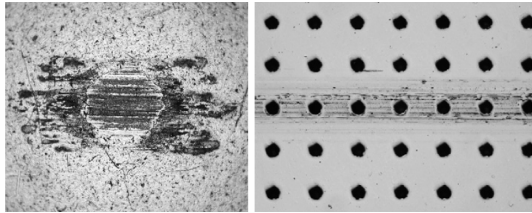

Friction for a smooth and laser-textured steel discs

- ❑ Reducing friction and wear under lubricated sliding conditions compared to smooth surfaces

Nélias et al. 2000

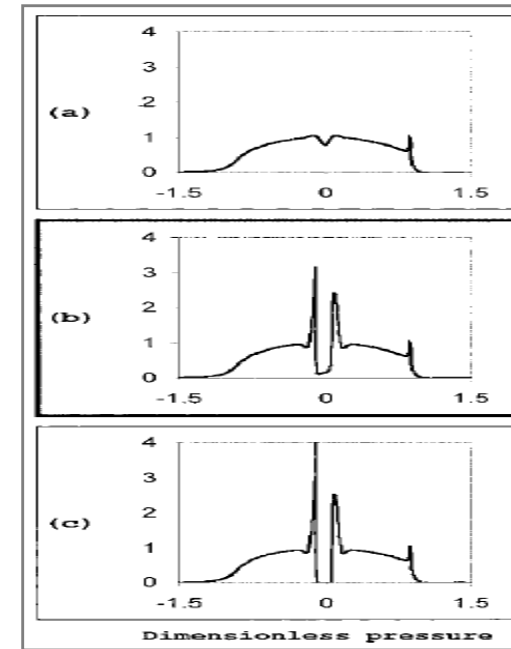

Effect of micro-dimples size on the contact pressure

- ❑ No effect for small size of micro-dimples.
- ❑ Positive effect for intermediate size (no cavitations)
- ❑ Negative effect for large size due to the cavitations.

STATE OF THE ART

Mourier et al. 2008

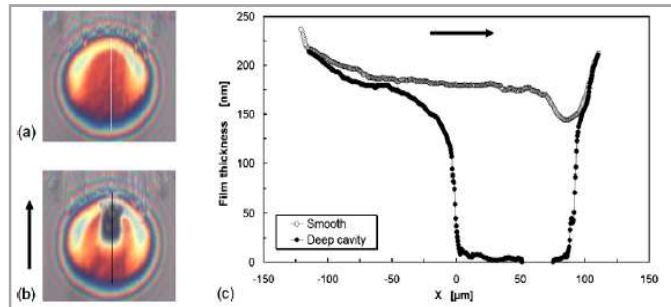

Deep micro-texture

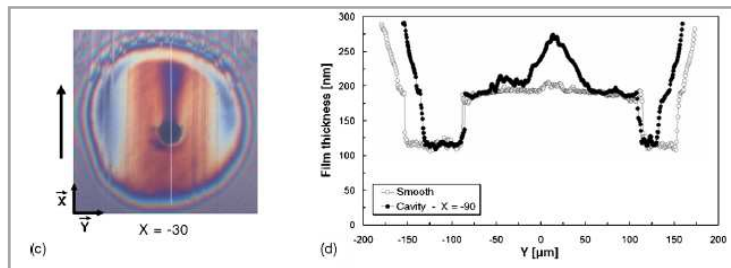

Shallow micro-texture

- ❑ Deep micro-cavities cause a reduction in film thickness.
- ❑ Shallow micro-cavities enhance film thickness.

Dumont et al. 2002

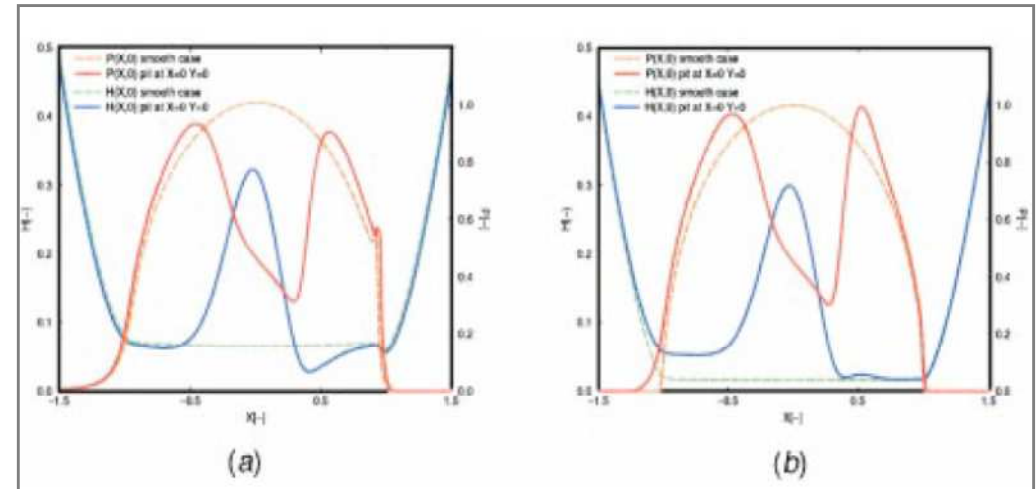

a) Fully flooded contact

b) Starved contact

- ❑ The beneficial effect on film thickness is lost as the contact becomes fully flooded.

Micro-textures in conformal contacts (hydrodynamic lubrication)

Etsion, I., "State of the Art in Laser Surface Texturing", ASME

Pettersson, U. and Jacobson, S., "Influence of Surface Texture on Boundary Lubricated Sliding Contacts", Tribology International

Zhao, J., Sadeghi, F. and Nixon, H., "A Finite Element Analysis of Surface Pocket Effects in Hertzian Line Contact", ASME Journal of Tribology

Kovalchenko, A., et al., "The Effect of Laser Surface Texturing on Transitions in Lubrication Regimes During Unidirectional Sliding Contact", Tribology International

COSTA, H. L.; HUTCHINGS, I. M. Hydrodynamic lubrication of textured steel surfaces under reciprocating sliding conditions. Tribology International, 2007.

RAMESH, Ashwin, et al. Friction characteristics of microtextured surfaces under mixed and hydrodynamic lubrication. Tribology International, 2013, 57: 170-176.

Micro-textures in EHL contacts

Coulon S, Jubault I, Lubrech AA, Ville F, Vergne P (2004) Pressure profiles measured within lubricated contacts in presence of dented surfaces. Comparison with numerical models. Tribol Int

Nelias D, Ville F (2000) Detrimental effects of debris dents on rolling contact fatigue. Trans ASME J Tribol

Mourier L, Mazuyer D, Lubrecht AA, Donnet C (2006) Transient increase of film thickness in micro-textured EHL contacts. Tribol Int

Ai XL, Cheng HS (1994) The influence of moving dent on point EHL contacts. Tribol Trans

Krupka I, Hartl M (2007) The effect of surface texturing on thin EHD lubrication films. Tribol Int

Micro-textures in starved EHL contacts

Dumont M, Lugt PM, Tripp JH (2002) Surface feature effects in starved circular EHL contacts. Trans ASME J Tribol

Undiscussed topics

Experimental study on the behavior of micro-textures in starved EHL contacts

Behavior of micro-textures in reverse and reciprocating motion in EHL contacts

AIM OF THESIS

Experimental and analytical investigations on the effects of shallow micro-textures (micro-dents and micro-grooves) on the coefficient of friction and film thickness in EHL contacts (ball-on-disc) under severe operating conditions and starved lubrication.

Experimental study on the effect of micro-dents on the coefficient of friction in sliding motion in non-conformal surfaces under starved lubrication.

Experimental study of micro-dents effects on film thickness under starved conditions.

Effect of transverse limited micro-grooves on friction and film thickness in reciprocating and reverse motion.

Numerical simulation to the behavior of transverse limited micro-grooves in EHL point contacts and experimental verification.

Comparing results with fully flooded conditions to ensure whether micro-dents are more effective under starved or fully flooded conditions.

Experimental study on the behavior of transverse limited micro-grooves with length less than Hertzian diameter through EHL contacts.

Effect of transverse limited micro-grooves on tribological performance under starvation.

Tribometer

- ❑ Simulator of the elastohydrodynamic contact
- ❑ Microscope equipped with a high speed camera
- ❑ Software for processing data and control

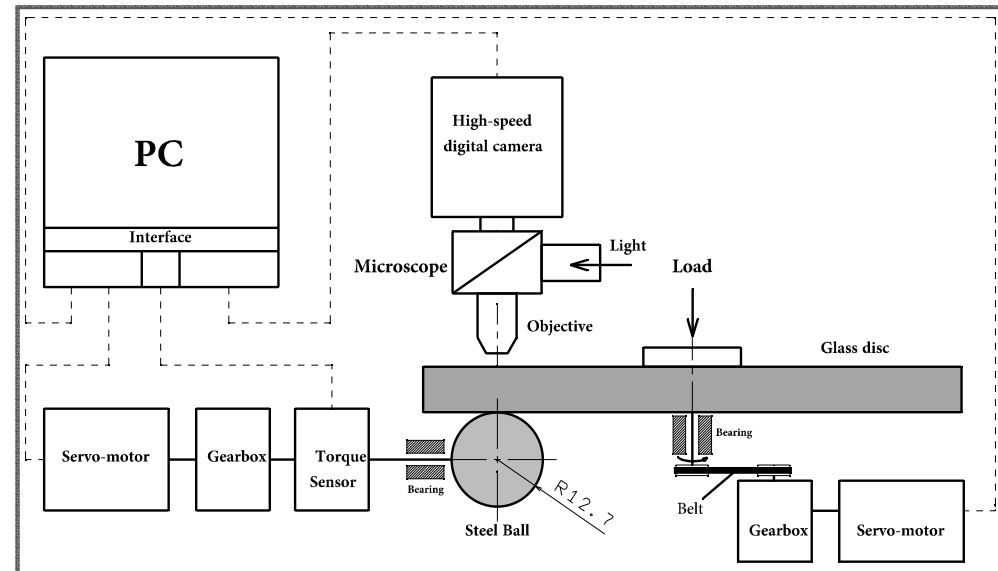

- ❑ Friction measurements in the EHL contact

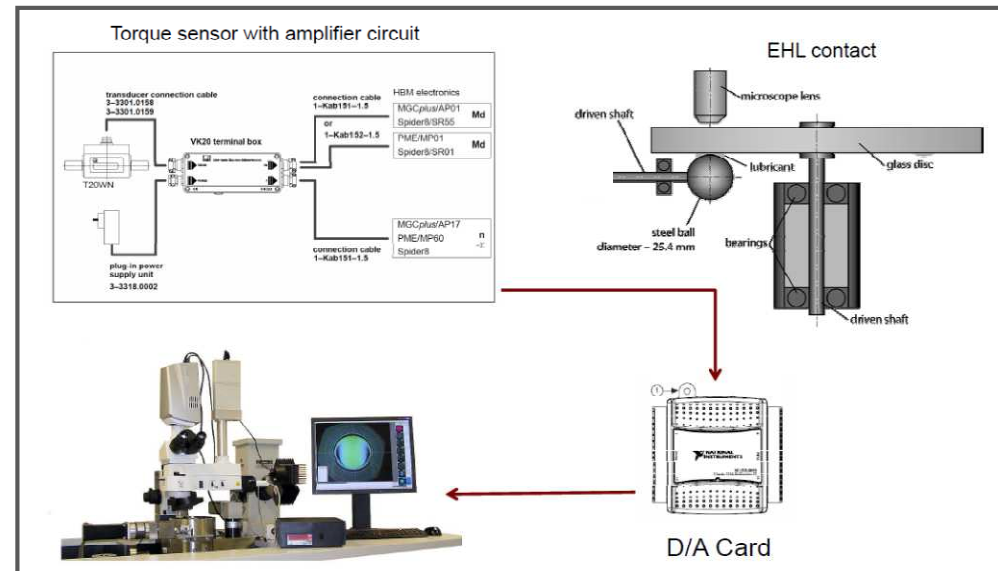

Film thickness measurement

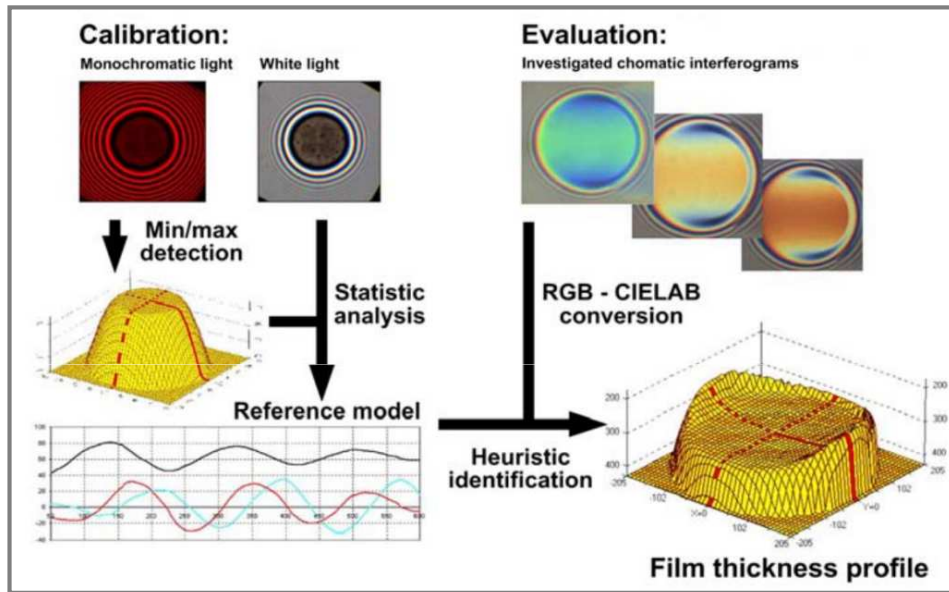

Film thickness measurement



Film colorimetric interferometry

Surface topography measurement

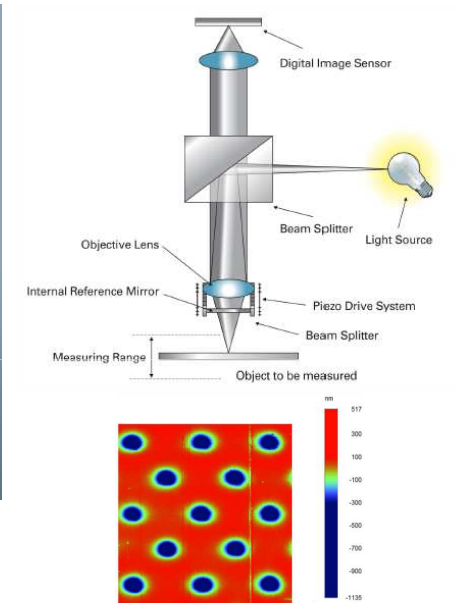
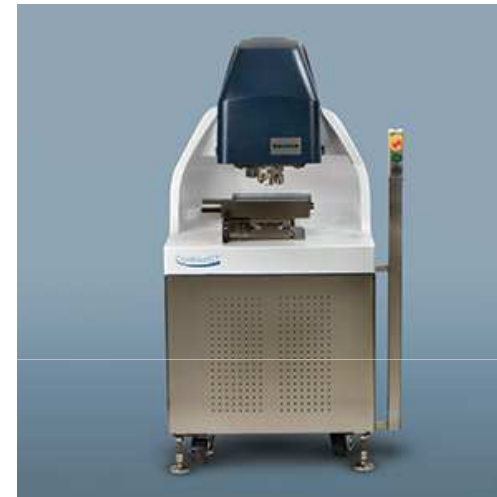

Surface topography measurement



White light Scanning Interferometry

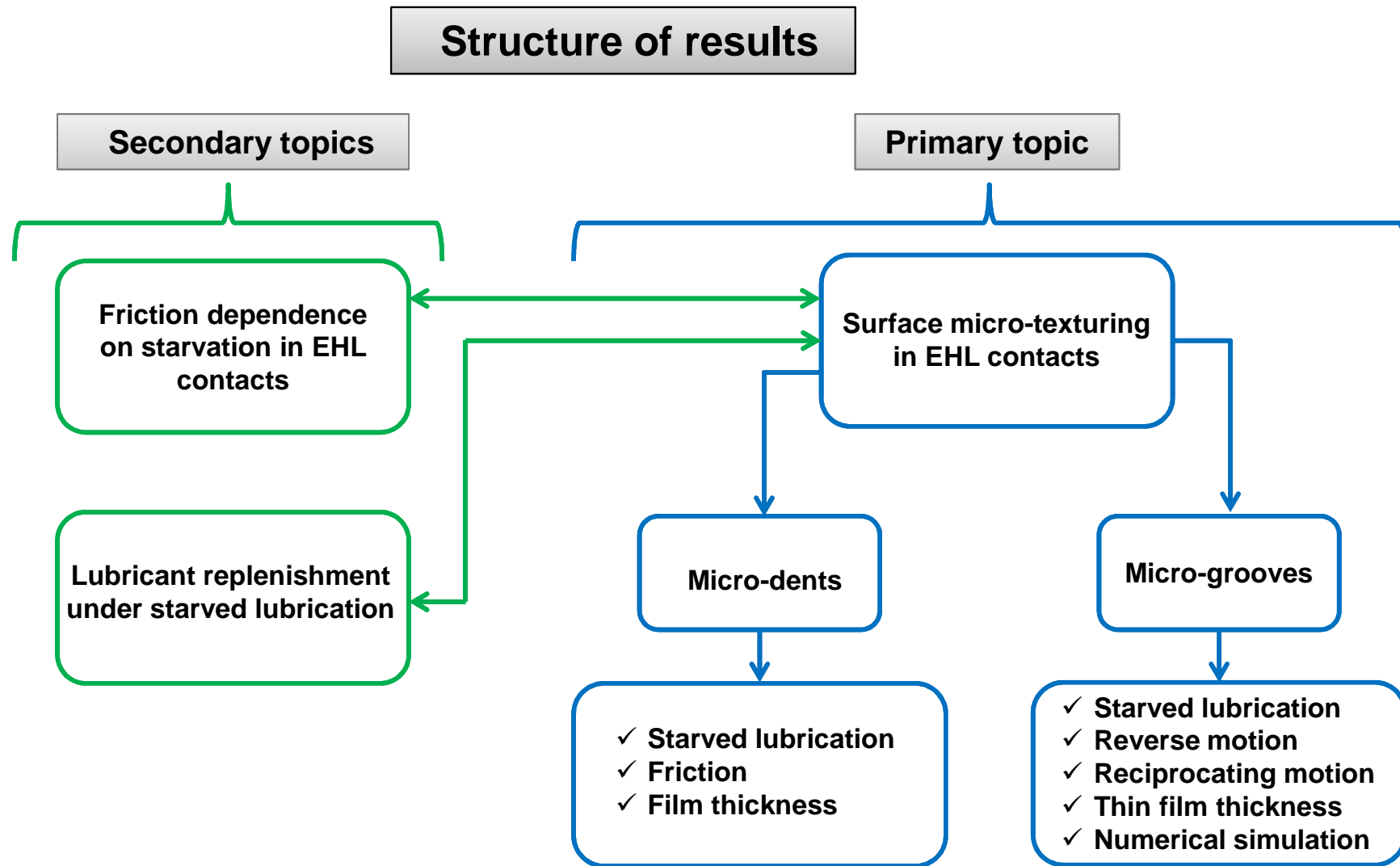

Friction dependence on starvation in EHL contacts

- Degree of starvation based on relative friction

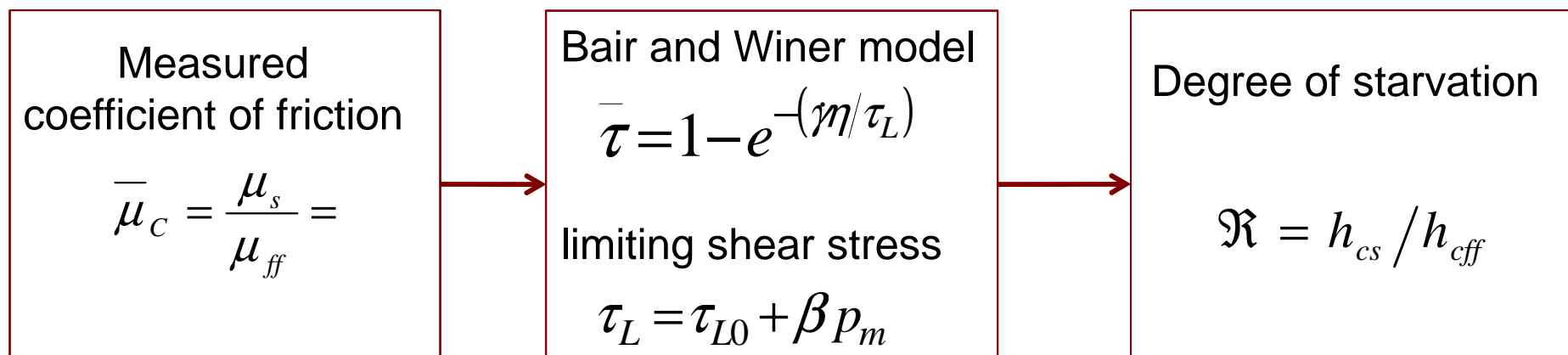
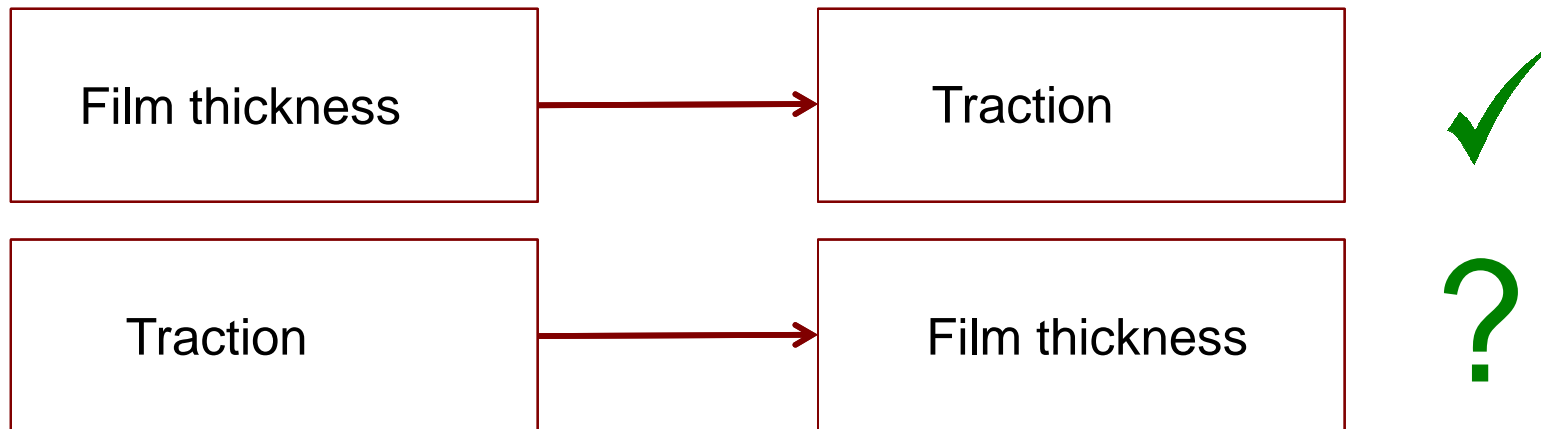

Friction dependence on starvation in EHL contacts

- Degree of starvation and relative friction

Measured degree of starvation

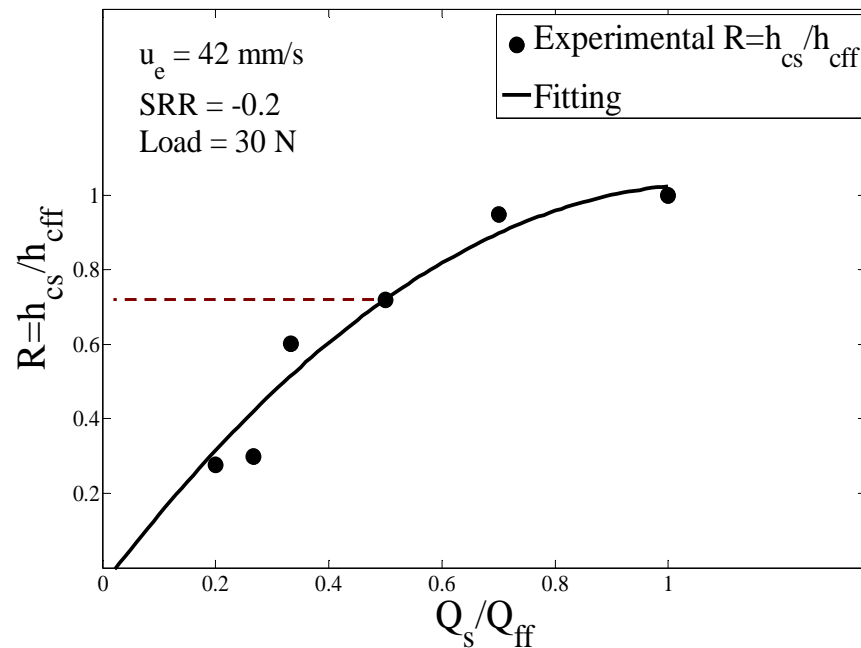

Degree of starvation based on friction

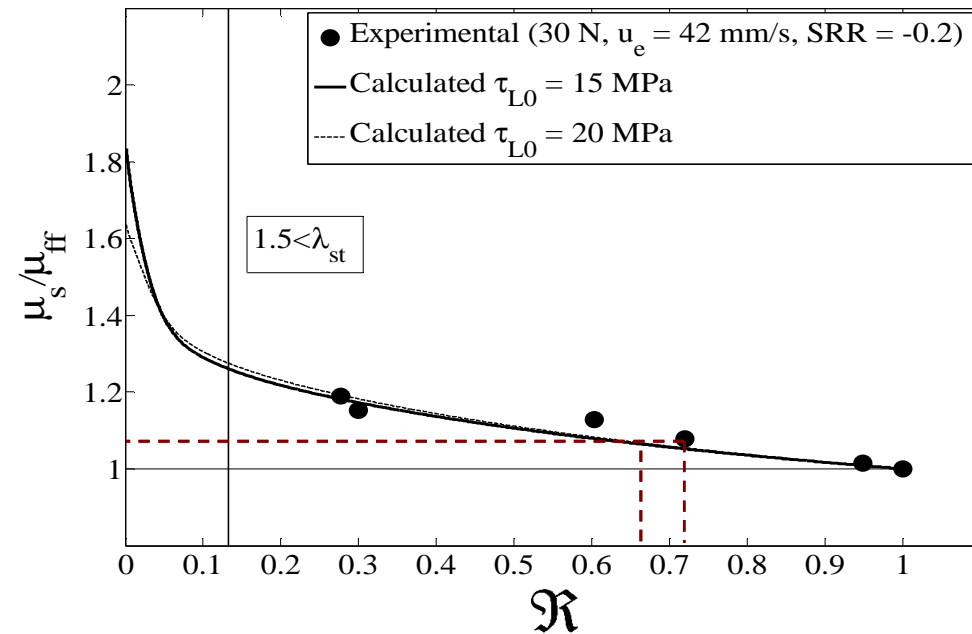

Lubricant replenishment under starved lubrication

Effect on film thickness for grease lubrication

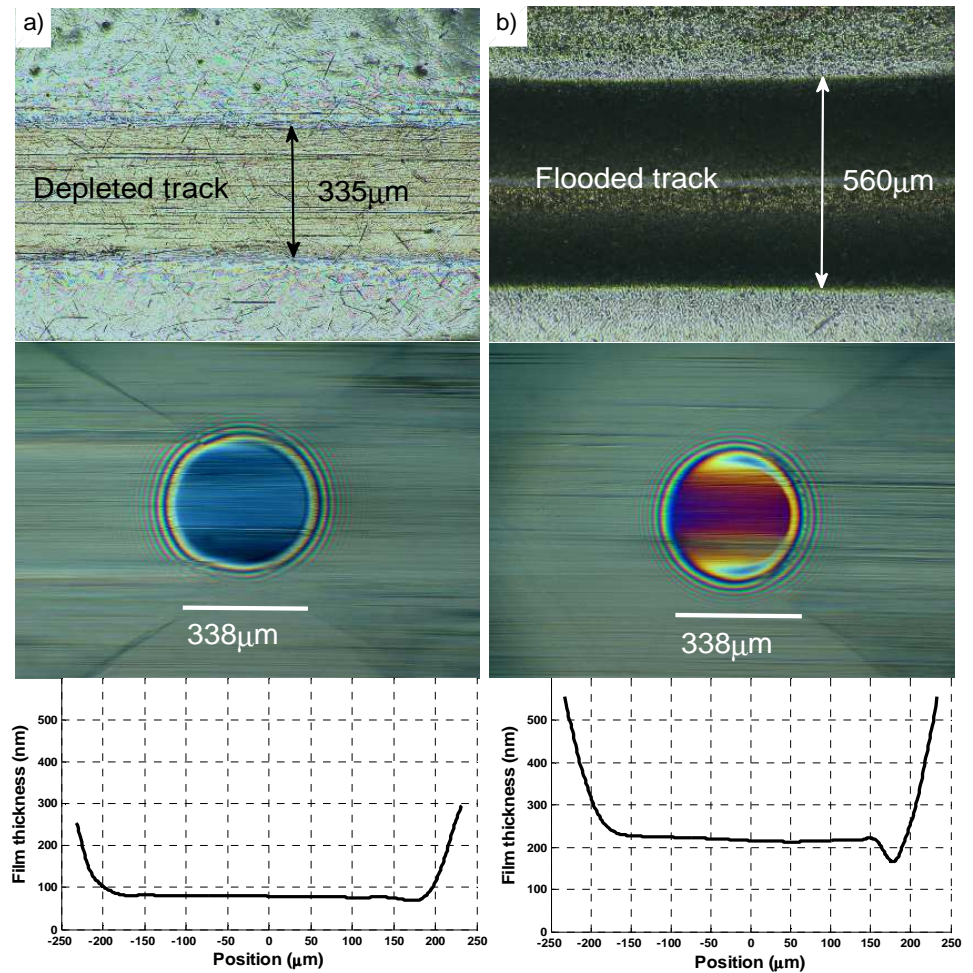
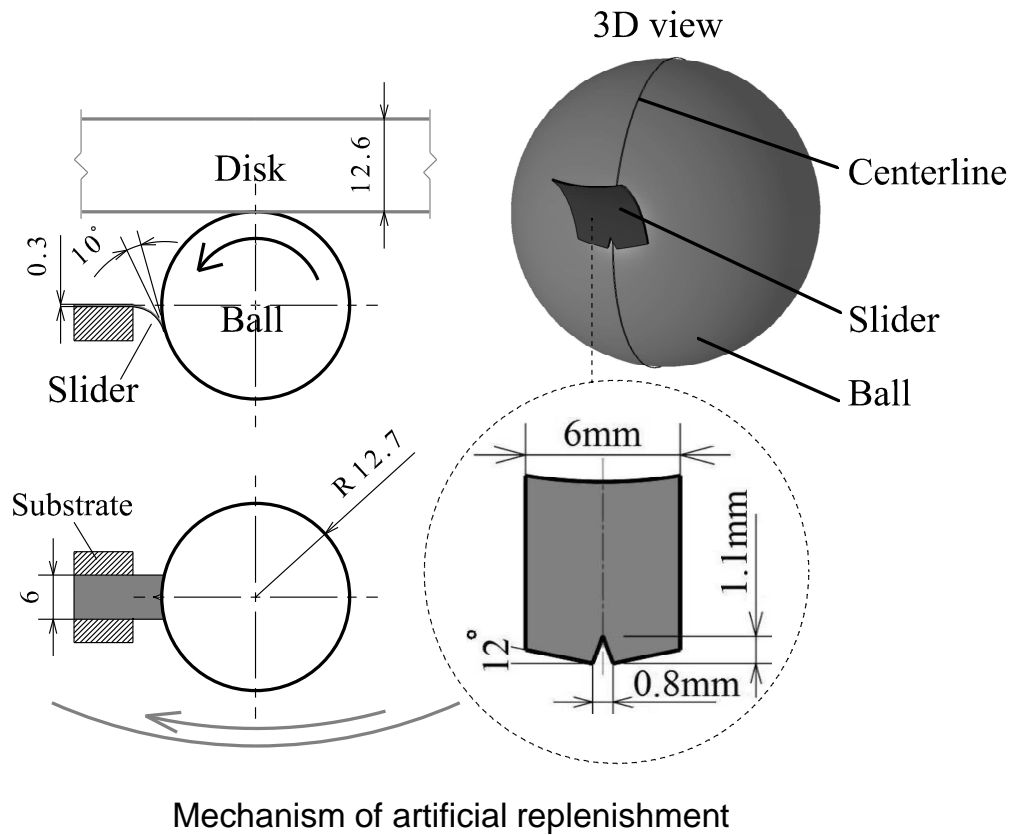

Optical microscope images of the overrolled track with the corresponding interferometric images and film thicknesses in the contact for grease lubrication with **a)** without induced replenishment **b)** with induced replenishment.

RESULTS AND DISCUSSION

Behavior of micro-dents under starvation

- Effect on coefficient of friction

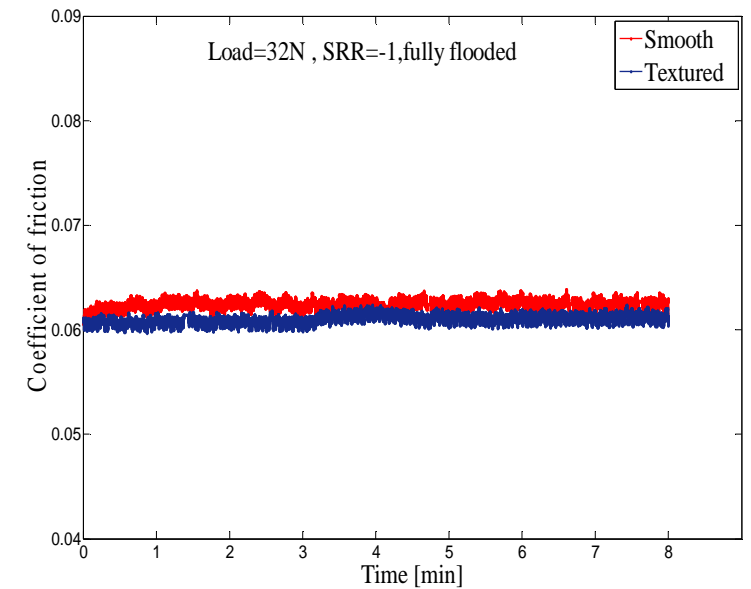
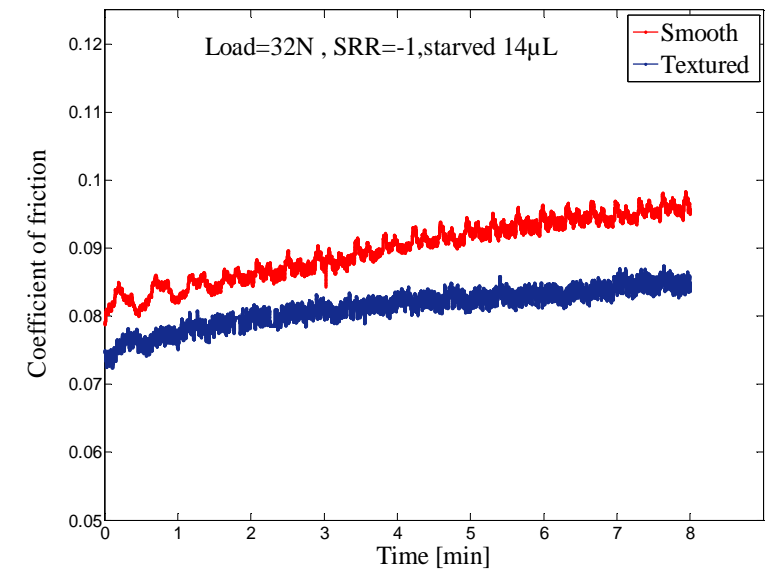
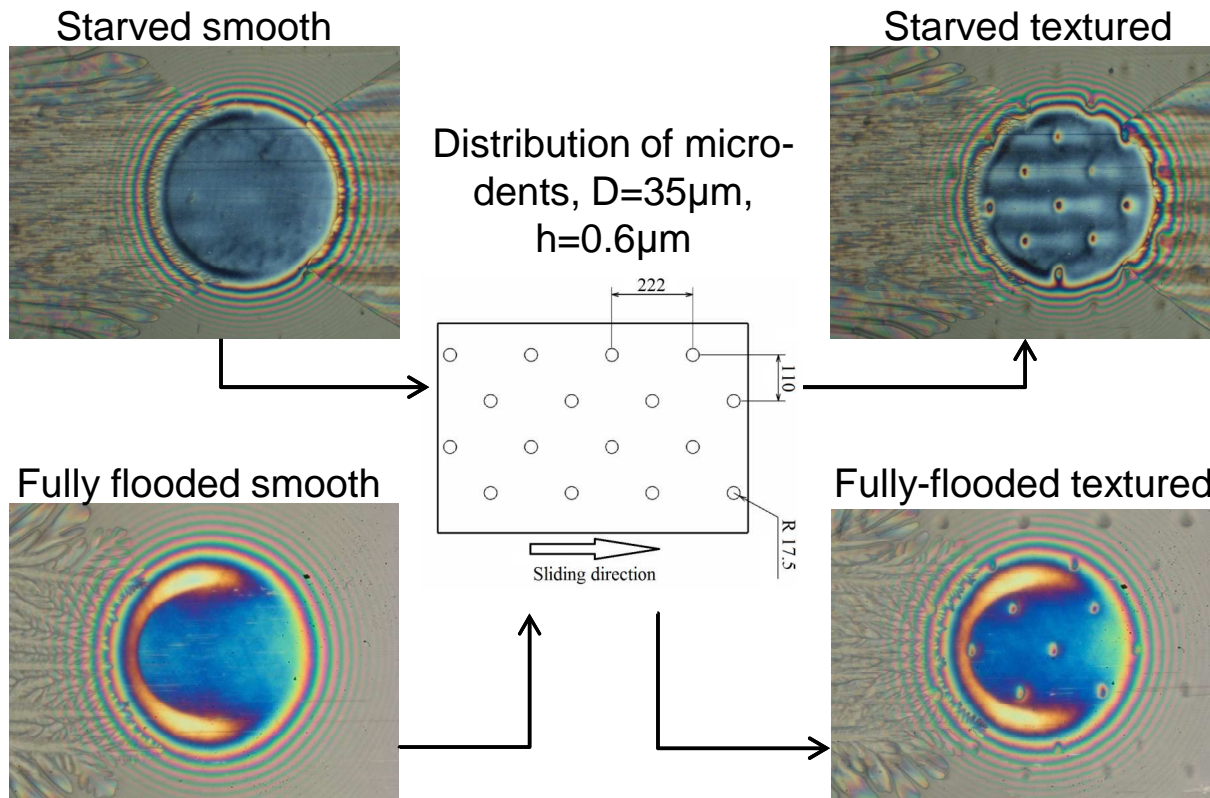

RESULTS AND DISCUSSION

Behavior of micro-dents under starvation

- Effect on film thickness

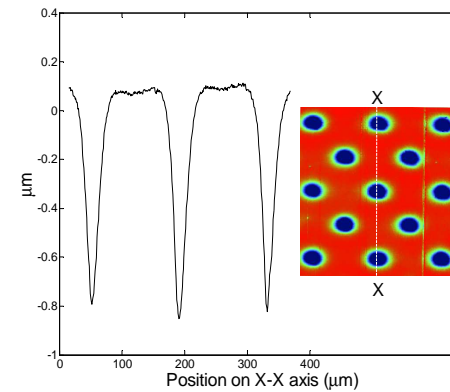

Profile and dimensions of micro-dents

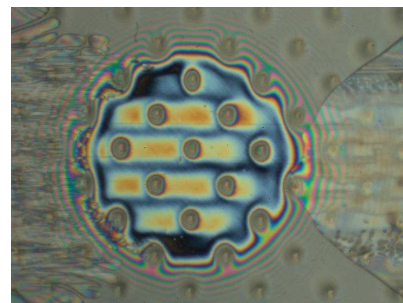
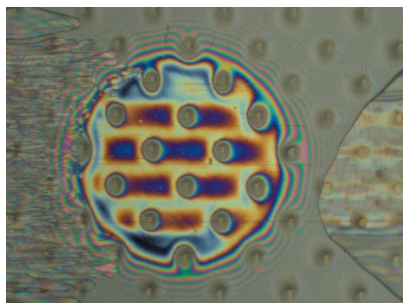
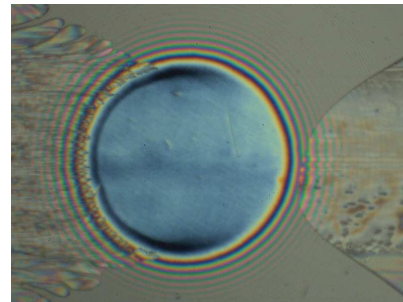
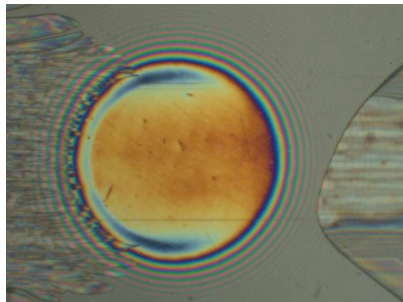

$u_e=9.5$ mm/s,
SRR= -1.75

$u_e=6.8$ mm/s,
SRR= -1.93

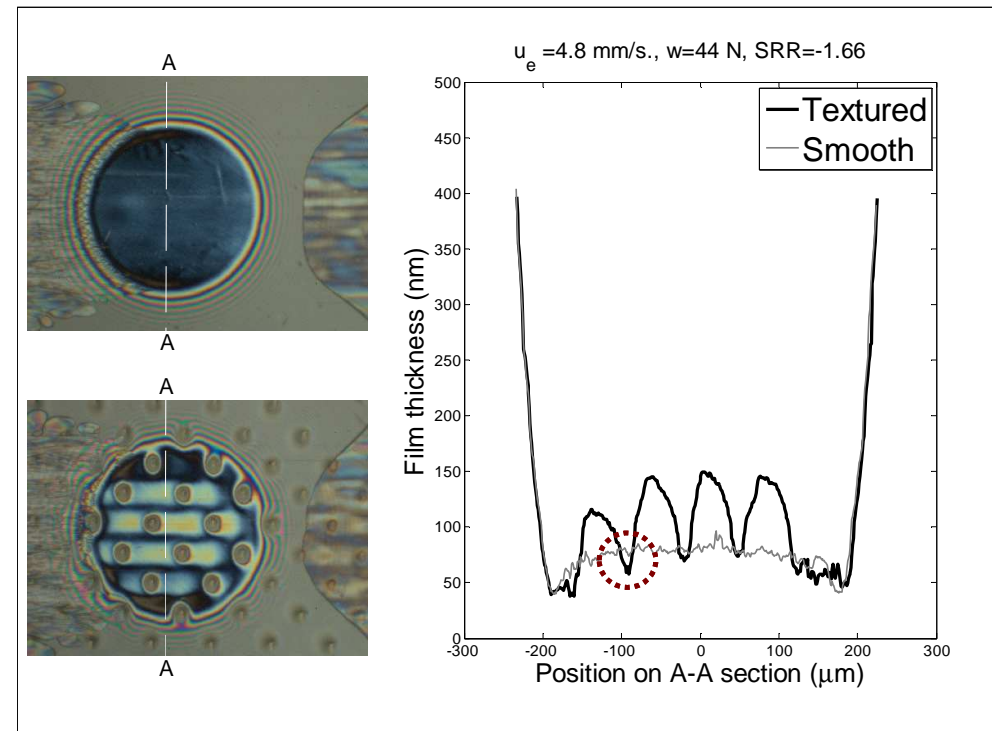

Load=44N, SRR=-1.66, $u_e=4.8$ mm/s, 8μ

RESULTS AND DISCUSSION

Behavior of transverse micro-grooves under starvation

- Effect on film thickness

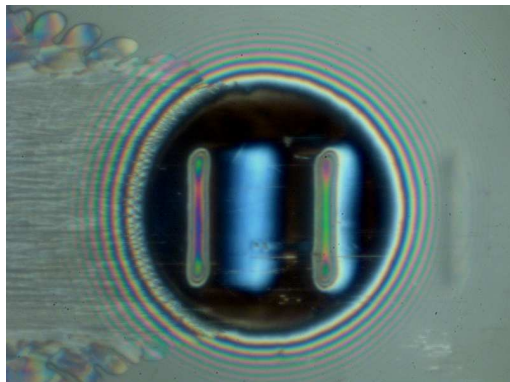
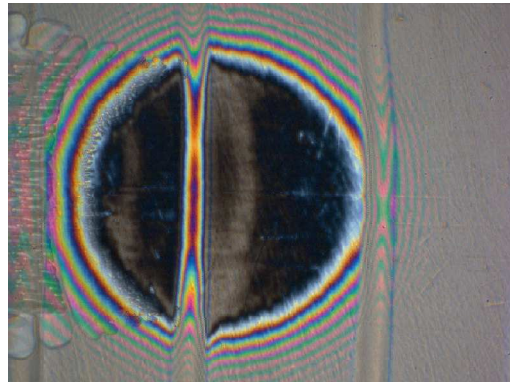

Closed vs. Opened micro-grooves

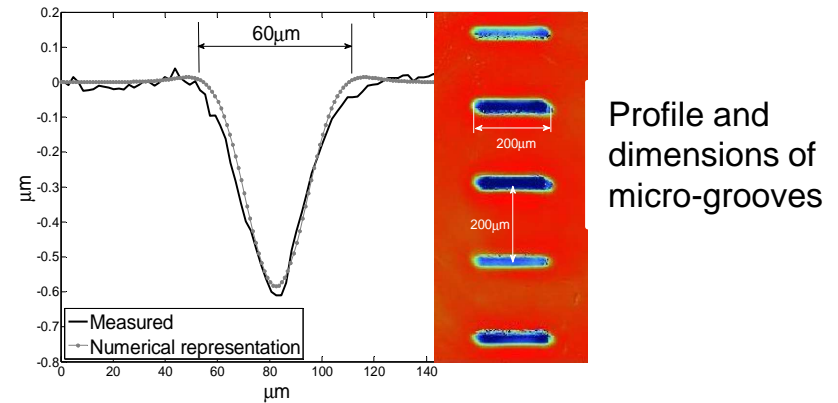

Profile and dimensions of micro-grooves

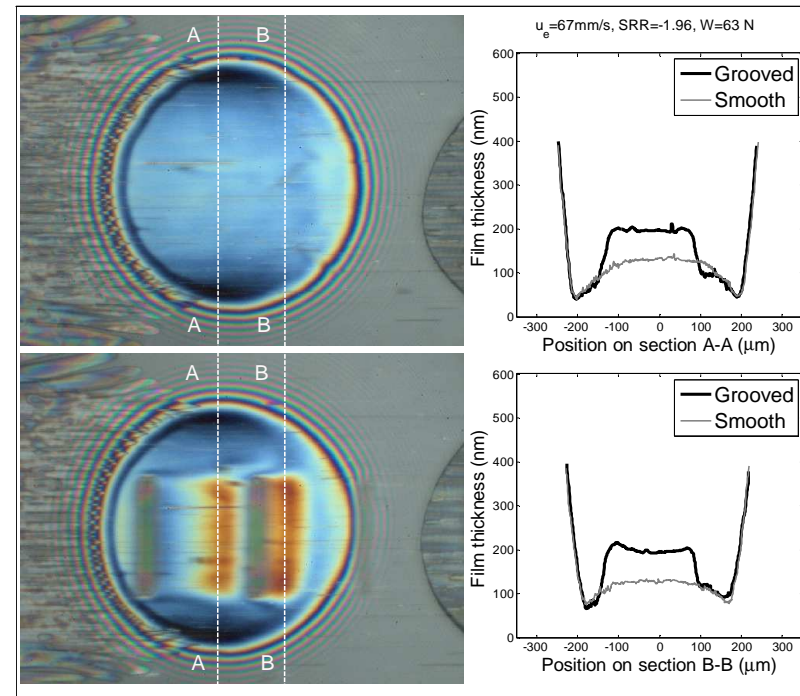

Load=63N, SRR=-1.96, $u_e=67$ mm/s, 8μ l

RESULTS AND DISCUSSION

Behavior of transverse micro-grooves under reverse motion

- Effect on film thickness and friction

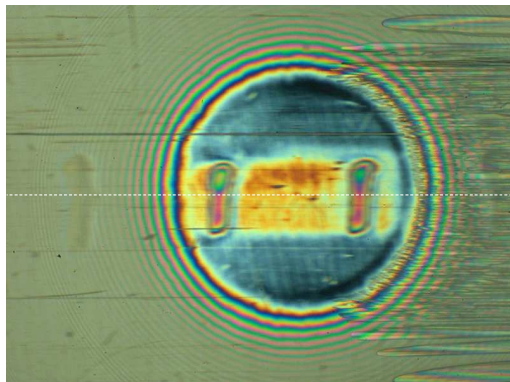
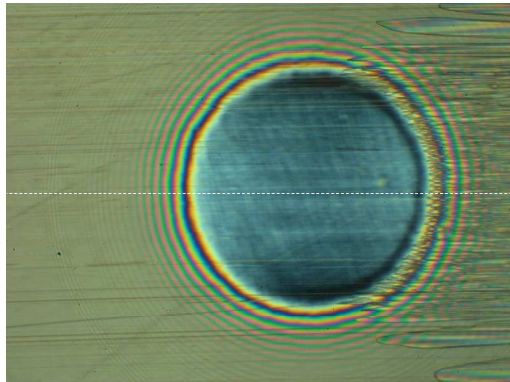

Load=40 N, $u_e = 2.9$ mm/s, SRR=-5.8

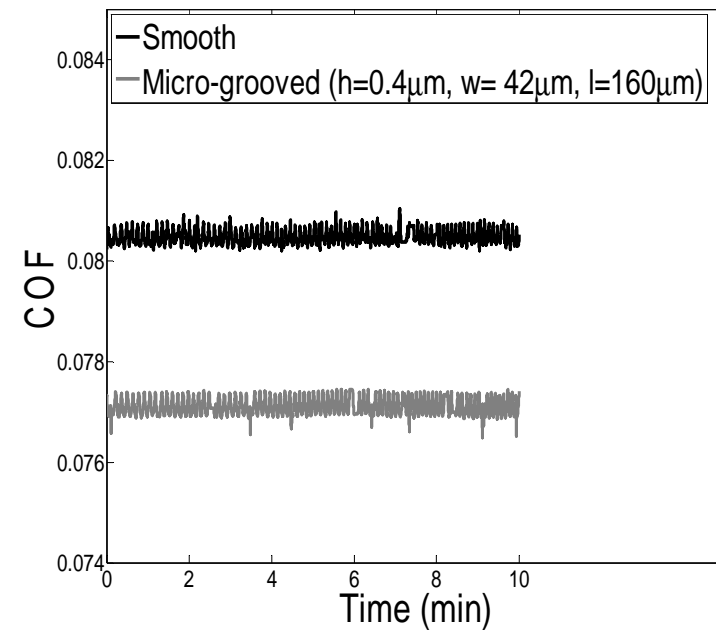
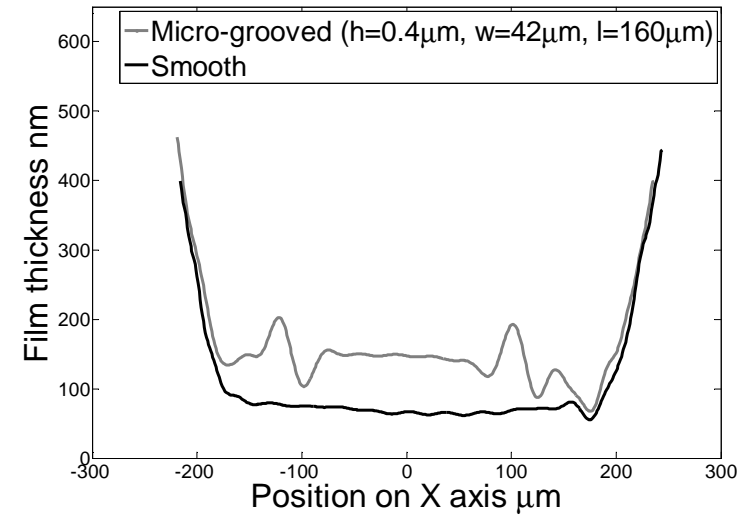

RESULTS AND DISCUSSION

Behavior of transverse micro-grooves in reciprocating motion

□ Effect on film thickness and friction

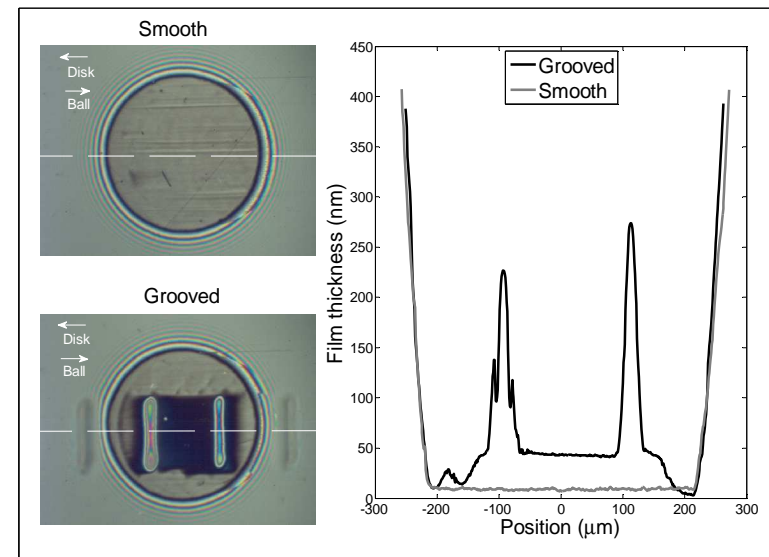
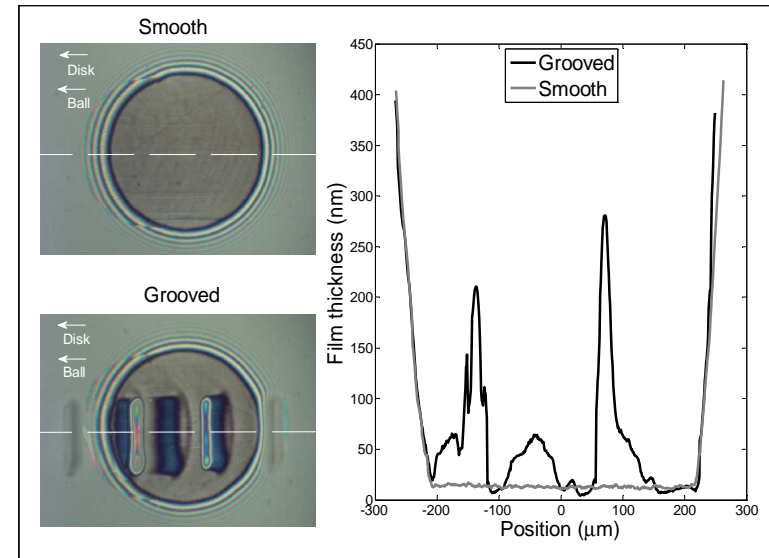
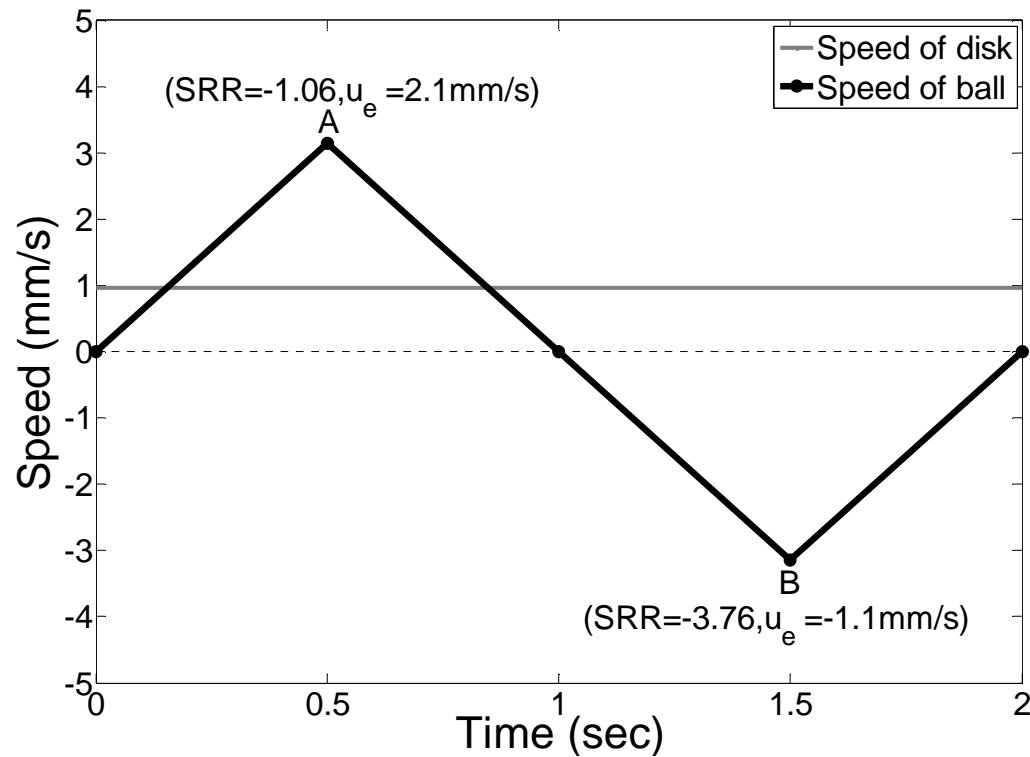

Numerical simulation of micro-grooves passage through EHL contact

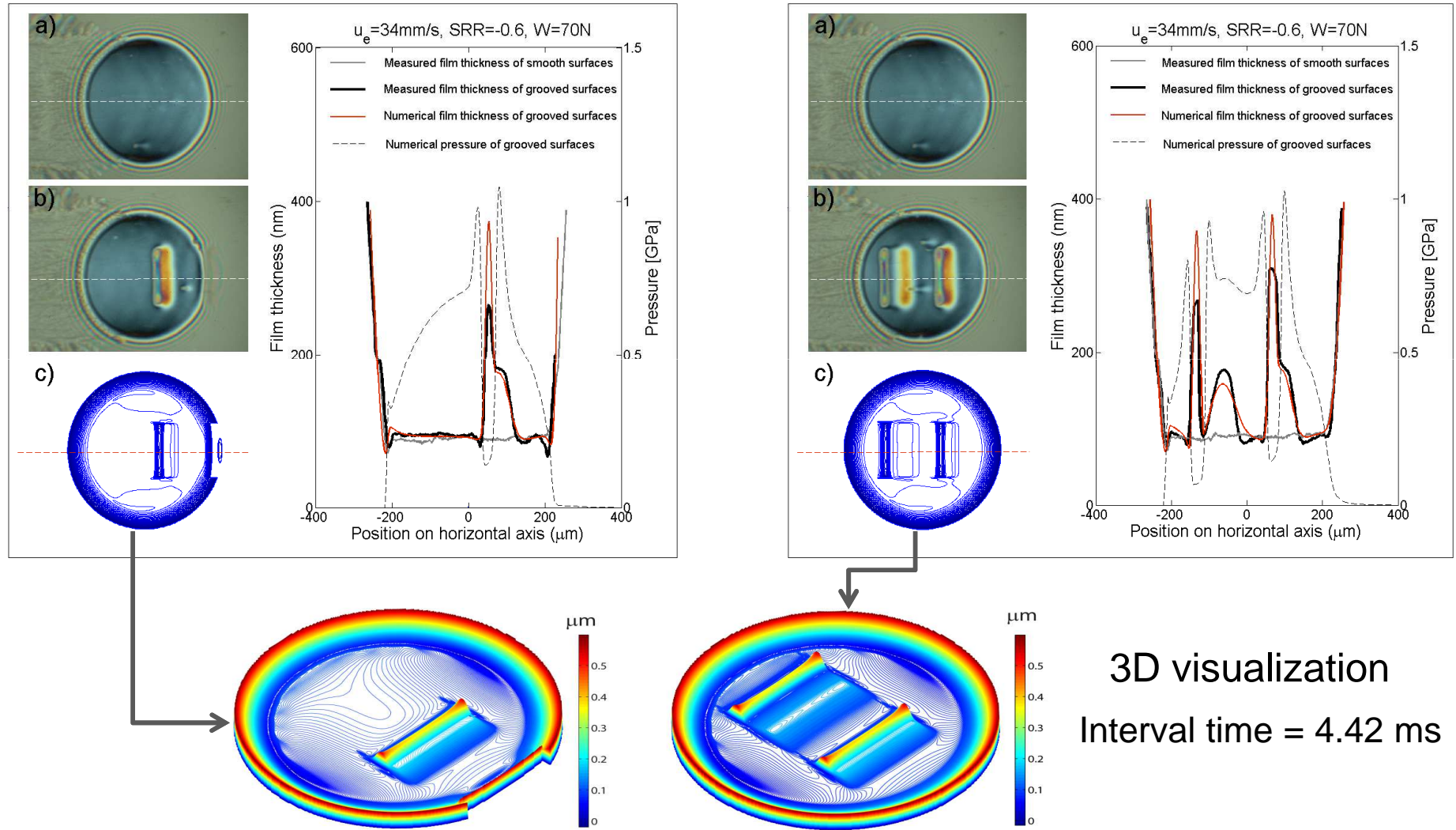

CONCLUSIONS

- The modification of non-conformal mating surfaces by shallow micro-dents provides a reduction of friction (about 9%) under severe starved lubrication.
- The benefits of micro-dents are negligible for fully flooded lubrication.
- Micro-grooves act as powerful oil reservoirs when they are introduced on the surface as closed texture cells with length less than the diameter of Hertzian contact.
- Transverse limited micro-grooves enhance significantly the film thickness of EHL contacts under thin films, reverse and reciprocating motion and under starved conditions.
- The behavior of limited micro-grooves in EHL contacts can be successfully predicted by numerical methods.

Publications

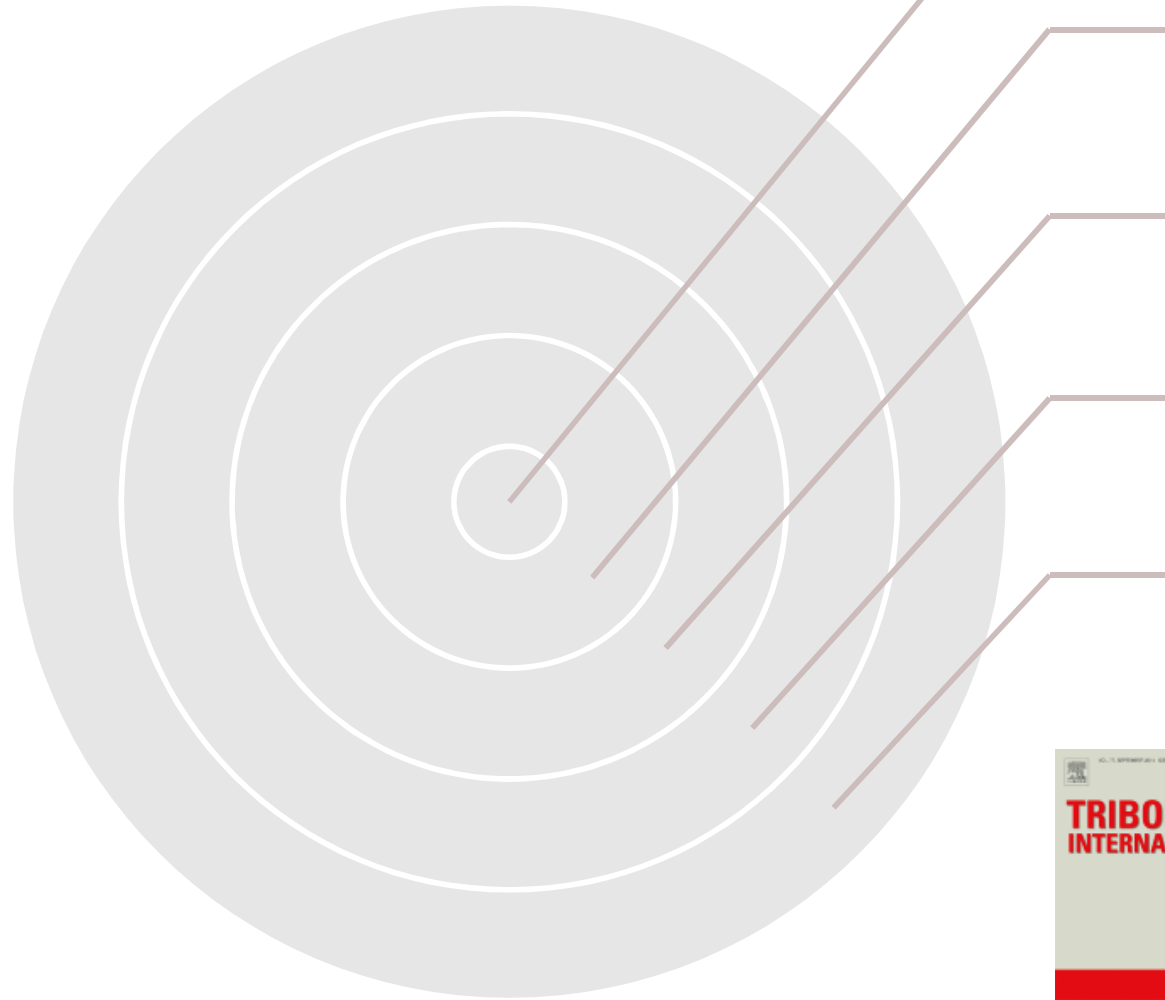

ALI, Fadi; et al. Experimental and numerical investigation on the behavior of transverse limited micro-grooves in EHL point contacts. *Tribology International*, 2015, 84: 81-89. **IF=2.124 (2014)**

ALI, Fadi; KŘUPKA, Ivan; HARTL, Martin. An Approximate Approach to Predict the Degree of Starvation in Ball-Disk Machine Based on the Relative Friction. *Tribology Transactions*, 2013, 56.4: 681-686. **IF=1.081 (2013)**

ALI, Fadi; KŘUPKA, Ivan; HARTL, Martin. Enhancing the parameters of starved EHL point conjunctions by artificially induced replenishment. *Tribology International*, 2013, 66: 134-142. **IF=2.124 (2013)**

ALI, Fadi; KŘUPKA, Ivan; HARTL, Martin. Reducing the friction of lubricated nonconformal point contacts by transverse shallow micro-grooves. *Proceedings of the Institution of Mechanical Engineers, Part J: Journal of Engineering Tribology*, 2014, 1350650114543317. **IF=0.613 (2013)**

ALI, Fadi; KŘUPKA, Ivan; HARTL, Martin. Analytical and experimental investigation on friction of non-conformal point contacts under starved lubrication. *Meccanica*, 2013, 48.3: 545-553. **IF=1.747 (2012)**



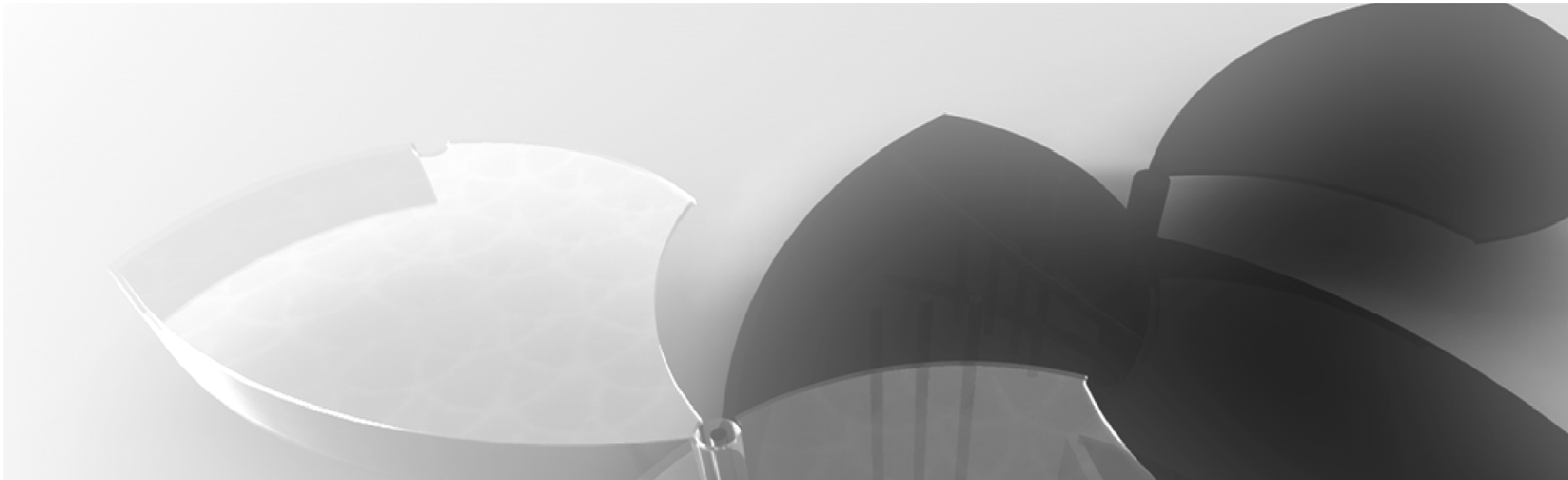

Thank you for attention

Fadi Ali



**Institute of Machine
and Industrial Design**

Institute of Machine and Industrial Design – Department of Tribology

Faculty of Mechanical Engineering

Brno University of Technology

Ph.D. Thesis Defense

July 24th, 2015, Brno